

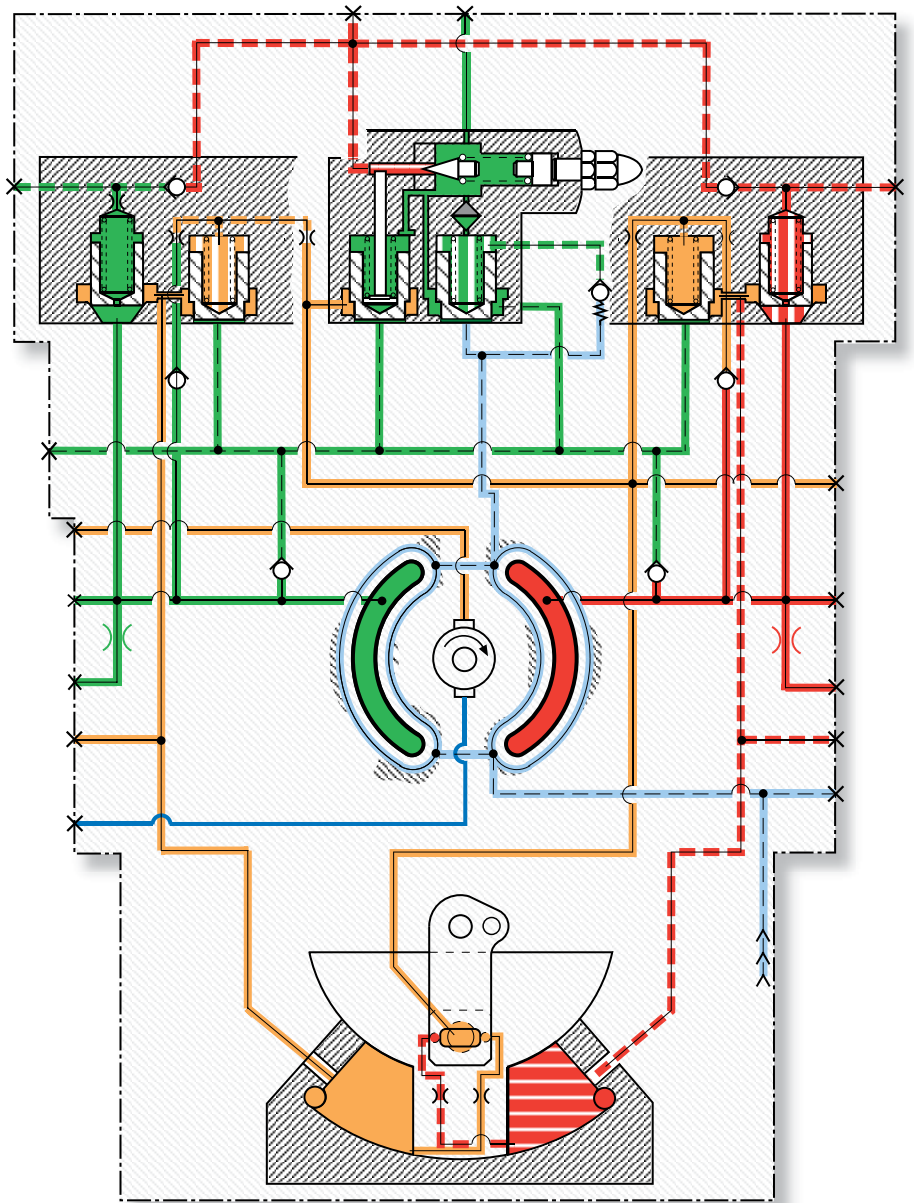

aerospace
climate control
electromechanical
filtration
fluid & gas handling
hydraulics
pneumatics
process control
sealing & shielding



Denison GOLD CUP® Application Handbook Piston Pumps & Motors

For Open & Closed Circuits

HY28-2668-01/GC/NA,EU
Effective: December 19, 2014



ENGINEERING YOUR SUCCESS.

Hydraulic Pump and Power Systems Division and Denison Hydraulics

The Hydraulic Pump and Power Systems Division of Parker Hannifin was formed in 2004 when our significant piston pump business was expanded through the acquisition of **Denison Hydraulics**. The addition of **Denison** allowed us to marry the wealth of knowledge that both companies have in the design, manufacture, and application of piston products in both open circuit and closed circuit system applications. Since before WWII, **Denison** products have been chosen for Military test stand applications and for shipboard hydraulic applications being recognized as technology leaders.

The heavy duty **GOLD CUP®** series of pumps and motors in this catalog represent a broadening of our product offering with hydrostatic transmission applications in marine, drilling, and shredding applications, among others. The tried and true design of the **GOLD CUP®** product line incorporates features such as integral servo and replenishing pump, hot oil shuttle, and a unique servo control system; all of which combine to provide a rugged self contained package which can withstand the harshest of conditions and continue to perform with trouble free long life.

The division is a leading worldwide manufacturer of hydraulic components and systems for earthmoving and construction vehicles; for mining equipment; for pulp and paper, chemical and other processing equipment; for ships and ordnance equipment; and for such in-plant machines as machine tools, plastic molding, die casters, and stamping presses.



The product information, specifications, and descriptions contained in this publication have been compiled for the use and convenience of our customers from information furnished by the manufacturer; and we can not, and do not, accept any responsibility for the accuracy or correctness of any description, calculation, specification, or information contained herein. No such description, calculation, specification, or information regarding the products being sold has been made part of the basis of the bargain, nor has same created or amounted to an express warranty that the products would conform thereto. We are selling the goods and merchandise illustrated and described on this publication on an "as is" basis, and disclaim any implied warranty, including any warranty of merchantability or warranty of fitness for any particular purpose whatsoever, with respect to the goods and merchandise sold. All manufacturer warranties shall be passed on to our customers, but we shall not be responsible for special, indirect, incidental, or consequential damages resulting from the use of any of the products or information contained or described on this publication. Further, we reserve the right to revise or otherwise make product improvements at any time without notification.



WARNING - USER RESPONSIBILITY

FAILURE OR IMPROPER SELECTION OR IMPROPER USE OF THE PRODUCTS DESCRIBED HEREIN OR RELATED ITEMS CAN CAUSE DEATH, PERSONAL INJURY AND PROPERTY DAMAGE.

This document and other information from Parker-Hannifin Corporation, its subsidiaries and authorized distributors provide product or system options for further investigation by users having technical expertise.

The user, through its own analysis and testing, is solely responsible for making the final selection of the system and components and assuring that all performance, endurance, maintenance, safety and warning requirements of the application are met. The user must analyze all aspects of the application, follow applicable industry standards, and follow the information concerning the product in the current product catalog and in any other materials provided from Parker or its subsidiaries or authorized distributors.

To the extent that Parker or its subsidiaries or authorized distributors provide component or system options based upon data or specifications provided by the user, the user is responsible for determining that such data and specifications are suitable and sufficient for all applications and reasonably foreseeable uses of the components or systems.

OFFER OF SALE

The items described in this document are hereby offered for sale by Parker-Hannifin Corporation, its subsidiaries or its authorized distributor. This offer and its acceptance are governed by the provisions stated in the detailed "Offer of Sale" elsewhere in this document.

INTRODUCTION

A reference text on the design & application of the GOLD CUP® line of Hydrostatic transmissions pumps & motors

The GOLD CUP® pump has four key features which set it apart and ahead of other hydrostatic pumps.

The first of these key features is the rocker cam and cradle assembly which provides for the variable displacement. The piston rotating group rides on the rocker cam. The cam and cradle assembly uses hydrostatic balance which provide a smooth displacement change, instead of relying on roller bearings or trunnions, which tend to transmit noise. The combination of the rigidity of the cam and cradle in addition to the hydraulic balance and lack of roller bearings provide lowest noise levels and hysteresis currently available. Position of the cam is accomplished by two stroking vanes which are mounted on either side of the cam and cradle assembly. The pressure loaded assemblies are part of the cam and provide a very direct precise means of controlling pump displacement. The lack of any mechanical linkages to a stroking piston eliminates mechanical wear and stress which can cause slow response, control degradation, or failure.

The second key feature is the unique servo control system. From the output of the servo pump thru the rotary servo control to the vane chamber, the control system provides a reliable control that compensates for change in system pressure and responds to changes in the input command almost instantly. When the displacement of the pump matches the command of the rotary servo, the control fluid is trapped in the vane chambers. Because of the compact size, the volume of the trapped fluid is very small and is very stable. As the command signal is changed, the pressure balanced rotary servo opens one set of vane chambers to the pump case, while directing servo oil to the other set of vane chambers. As the cradle moves to the position commanded by the rotary servo, the vane ports which are connected to the cradle assembly provide the feedback to once again block the servo passages in and out of the vane chamber. The pressure balance of the rotary servo stem insures that only minimal torque is required for the input signal. The close tolerance between the vane chamber ports and the servo stem insures that any error signal is instantly corrected. The servo stem is controlled by an external signal to the servo shaft providing an input command through an arc of +19° to -19°. Additional controls are readily available and are discussed in further detail later.

The third key feature is the servo pressure control. The servo pressure is determined by the servo relief valve. Since replenishing oil is first directed to the servo system, total control is always insured. A pressure modulating pin causes the servo pressure to increase as the system pressure increases at a rate of 40 psi, 2,8 bar servo pressure per 1000 psi, 69 bar system pressure. This increase in servo pressure adds to the rigidity of the servo system as the pump experiences increasing load.

The fourth key feature is the large barrel bearing. This bearing absorbs the mechanical imbalance caused by the forces of the pistons against the angled cam assembly. Thus the barrel is held squarely against the port plate eliminating the possibility of barrel "tipping" or separating from the port plate. This design eliminates the need for a large shaft bearing and consequently reduces the size of the bore circle.

The resulting component designs proved to be a unique approach in the areas of displacement control mechanisms and control circuits. This manual is an attempt to convey an understanding of these concepts and mechanisms to the design engineering personnel who will be using this equipment in the design of new machinery. This manual, therefore, assumes a level of understanding of hydrostatic transmissions and hydraulic circuitry and does not attempt to explain basic concepts.

The information contained in this manual is intended to be supplemented by specific detailed information contained in sales brochures and service brochures.

SECTION 1GOLD CUP® package pump and motor
internal configuration

The GOLD CUP® package pump and motor internal configuration	1.1
Package pump internal configuration	1.1
Figure 1.1 Pump internal configuration-rotating group	1.1
Figure 1.2 Stroking vane assembly	1.2
Figure 1.3 Stroking vane installation	1.2
Figure 1.4 Pump internal configuration vane chambers and servo stem	1.3
Figure 1.5 Pump internal configuration vane chamber cover and servo plates	1.3
Figure 1.6 Vane chamber covers	1.3
Figure 1.7 Pump internal config. rotary servo input and displacement indicator	1.4
Figure 1.8 Control cover - rotary servo input	1.4
Figure 1.9 Ring check assembly	1.5
Package motor configuration	1.5
Figure 1.10 Fixed displacement motor	1.5
Figure 1.11 Variable displacement motor	1.6

SECTION 2

GOLD CUP® circuitry

GOLD CUP® circuitry	2.1
Package pump circuitry	2.1
Figure 2.1 Poppets	2.1
Servo & replenishing circuits	2.1
Pressure compensator override	2.2
Figure 2.2 6.0, 7.25 and 8.0 in ³ /rev. pump circuit	2.4
Figure 2.2.1 6.0, 7.25 and 8.0 in ³ /rev. pump circuit (ISO standard)	2.5
Nomenclature for ISO circuit figure 2.2.1	2.6
Figure 2.3 11, 14 pump circuit	2.7
Figure 2.3.1 11, 14 pump circuit (ISO standard)	2.8
Nomenclature for ISO circuit figure 2.3.1	2.9
Figure 2.4 24, 30 pump circuit	2.10
Figure 2.4.1 24, 30 pump circuit (ISO standard)	2.11
Nomenclature for ISO circuit figure 2.4.1	2.12
Package motor circuitry	2.13
Figure 2.5 GOLD CUP® package motor circuit	2.13

SECTION 3

GOLD CUP® controls

GOLD CUP® controls	3.1
Rotary servo input	3.2
Figure 3.1 Control cover-rotary servo input	3.2
Spring centering rotary servo	3.3
Figure 3.2 Spring centered rotary servo (zero stroke)	3.3
Figure 3.3 Spring centered rotary servo (on stroke)	3.3
Adjustable stops	3.4
Manual screw adjustment	3.4
Figure 3.4 Manual screw adjustment	3.4
Motor cylinder control	3.4
Figure 3.5 Motor cylinder control (max. stroke)	3.5
Figure 3.6 Motor cylinder control (min. stroke)	3.5
Pump two position cylinder control	3.6
Figure 3.7 Pump two position cylinder control	3.6
Pump three position cylinder control	3.6
Figure 3.8 Pump three position cylinder control	3.7
Motor electrohydraulic cylinder control (2M* motor control)	3.7
Figure 3.9 Motor electrohydraulic cylinder control (full stroke)	3.7
Pump two position electrohydraulic cylinder control (2M* pump control)	3.7
Figure 3.10 Pump two position electrohydraulic cylinder control	3.8
Pump three position electrohydraulic cylinder control (2N* control)	3.8
Figure 3.11 Three position electrohydraulic cylinder control	3.8
Automatic brake and neutral bypass control	3.9
Figure 3.12 Automatic brake and neutral bypass (400 and 500 series) (input & output at zero stroke)	3.9
Figure 3.13 Automatic brake and neutral bypass (400 and 500 series) (input and output on stroke)	3.10
Figure 3.14 Automatic brake and neutral bypass (400 and 500 series) (input zero, output on stroke)	3.11
Figure 3.15 Automatic brake and neutral bypass (800 and 900 "C" series) (zero stroke)	3.12
Figure 3.16 Automatic brake and neutral bypass (800 and 900 "C" series) (full stroke)	3.12
Torque limit override control	3.12
Figure 3.17 Torque limit override circuit	3.13
Figure 3.18 Torque limit override shoe	3.13
Figure 3.19 Torque (horsepower) limit override	3.14

SECTION 3

GOLD CUP® controls (continued)

Electrohydraulic stroker (500 series)	3.14
Figure 3.20 Electrohydraulic stroker (zero stroke).....	3.14
Figure 3.21 Electrohydraulic stroker (on stroke).....	3.15
Figure 3.22 Stroke vs. current	3.15
Hydraulic stroker (800 series).....	3.15
Figure 3.23 Hydraulic stroker (centered)	3.16
Figure 3.24 Hydraulic stroker (on stroke)	3.16
Electrohydraulic servo (HI IQ) (700 series)	3.17
Figure 3.25 Electrohydraulic servovalve (HI-IQ).....	3.17
Electrohydraulic stroker (900 series)	3.17
Figure 3.26 900 series hydraulic circuit.....	3.18

SECTION 4

GOLD CUP® application suggestions

Introduction.....	4.1
Remote control of pressure compensator override	4.1
Figure 4.1 Circuit to control speed of venting compensator	4.1
Figure 4.2 Remote control of multiple PCOR	4.1
Figure 4.3 Remote control of PCOR by pressure sources	4.2
Load sensing	4.2
Figure 4.4 Load sensing.....	4.2
Constant speed drives	4.3
Figure 4.5 Constant speed drive	4.3
Dead man control	4.3
Overhauling load-dynamic braking	4.3
Replenishment requirements.....	4.4
Figure 4.6 Case pressure replenishment circuit	4.4
Figure 4.7 Additional replenishment flow.....	4.5
Engine startup	4.5
Cold startup	4.5
New system or new component startup	4.6
System filtration	4.6
Cleaning procedures	4.7
Shaft type selection	4.7
Applying splined shafts.....	4.8
Applying keyed shafts.....	4.8

SECTION 5

GOLD CUP® performance curves

Series6 Variable volume pump with 1.07 in ³ /rev., 17,5 cc/rev. aux. pump.....	5.1
Series6 Variable volume motor.....	5.2
Series7 Variable volume pump with 1.07 in ³ /rev., 17,5 cc/rev. aux. pump.....	5.3
Series7 Variable volume motor.....	5.4
Series8 Variable volume pump with 1.07 in ³ /rev., 17,5 cc/rev. aux. pump.....	5.5
Series11 Variable volume pump with 2x1.07 in ³ /rev., 2x17,5 cc/rev. aux. pump	5.6
Series11 Variable volume motor.....	5.7
Series14 Variable volume pump with 2x1.07 in ³ /rev., 2x17,5 cc/rev. aux. pump	5.8
Series14 Variable volume motor.....	5.9
Series24 Variable volume pump with 2.81 in ³ /rev., 46 cc/rev. aux. pump.....	5.10
Series24 Variable volume motor.....	5.11
Series30 Variable volume pump with 2.81 in ³ /rev., 46 cc/rev. aux. pump.....	5.12

SECTION 6

Reference information

Fluid power formulas	6.1
Pg1 Pump ordering code.....	6.2
Pg2 Pump ordering code.....	6.3
Pg1 Motor ordering code.....	6.4
Pg2 Motor ordering code.....	6.5
Pump control combinations	6.6
Motor control combinations	6.7

SECTION 7

Offer of Sale

Notes	7.1
Offer of Sale	7.2

**GOLD CUP® PACKAGE PUMP
AND MOTOR INTERNAL
CONFIGURATION**

**PACKAGE PUMP INTERNAL
CONFIGURATION**

GOLD CUP® series package pumps and motors are equipped with all the components required by most hydrostatic transmission circuits. In the pump are the main system rotating group, the servo and replenishing pump(s), replenishing check valves, stroking mechanisms, and a valve block assembly containing the servo pressure relief valve, replenishing pressure relief valve and the pressure compensator override valving. The package motor contains the hot oil shuttle valve and the low pressure replenishing relief valve along with the main system motor rotating unit. The circuitry and operation of these valves are detailed in the GOLD CUP® circuitry chapter of this manual.

GOLD CUP® hydrostatic transmission pumps are equipped with the following standard features:

- (1) rotary servo displacement control
- (2) pressure compensator override
- (3) servo and replenishing pump(s)
- (4) servo pressure relief valve
- (5) replenishing pressure relief valve
- (6) full flow replenishing check valves
- (7) displacement indicator

Figure 1.1 shows the main rotating group and the auxiliary pump(s). The main system pump rotating group is an axial piston variable volume pump consisting of a shaft driven cylinder barrel and pistons. The barrel is made of steel with bronze liners in the cylinder bores. It is supported by a large diameter roller bearing located in line with the radial forces generated by the pumping action. Because of its location, this bearing prevents the barrel from tipping at high speeds and high pressures and gives the pump its high speed and pressure capabilities. If the cylinder barrel is allowed to tip, the balancing areas will be altered and the barrel will be more susceptible to blow-off. Tipping also increases internal leakage and reduces efficiency.

The 6.0, 7.25, 8.0, 11 and 14 in³/rev units all have seven pistons with bronze shoes. The 24 and 30 in³/rev units have nine. A retainer plate holds the piston shoes to the rocker cam creep plate and is itself held to the rocker cam snout by a snap ring and thrust bearing.

A small auxiliary drive shaft is splined to the cylinder barrel and drives the auxiliary pump(s). On the 6.0 thru 14 in³/rev, this shaft also provides cylinder barrel holddown and initial clamping of the auxiliary pump(s) pressure loaded side plate. Holddown and clamping forces are set by a spring between the shaft and the cylinder barrel, and adjusted by the nut on the other end of the shaft.

Figure 1.1
GOLD CUP® pump internal
configuration - rotating group

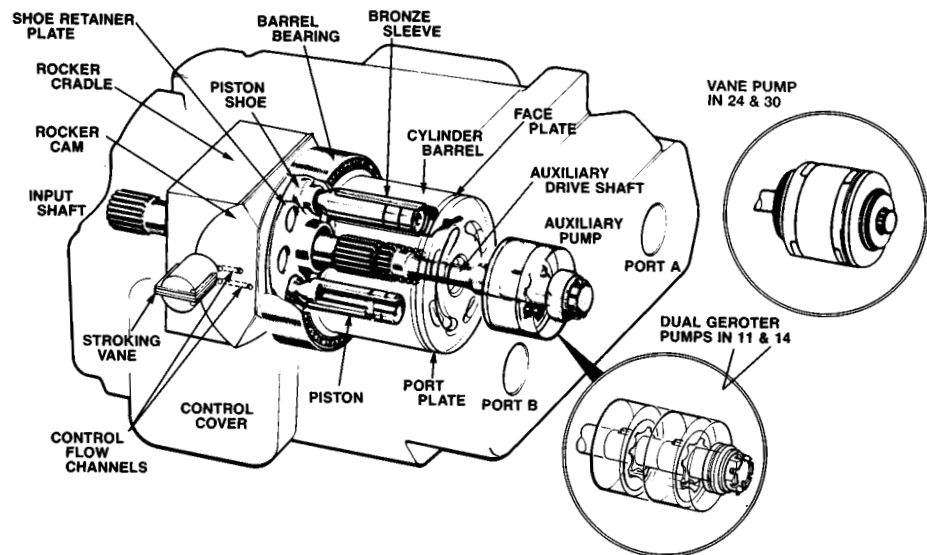

The input shaft passes through the rocker cam and cradle assembly and is splined to the cylinder barrel. It is available in the following standard configurations:

- SAE spline shaft
- SAE key shaft

The shaft normally accepts only torsional loads and is not rated for axial and radial loads imparted by external drive configurations. The displacement of the main system pump is varied by the rocker cam which rotates in the rocker cradle. Both cam and cradle are loaded in compression and are very rigid. They do not deflect as do bearing supported trunnions. This reduction in deflection reduces transmitted noise and increases efficiency. To reduce friction and the required higher servo pressure, the rocker cam is partially floated by system pressure exposed to a small area of the cradle surface.

Integrally cast on either side of the rocker cam are a pair of posts to hold the stroking vanes. The vanes are held in slots in the posts and each consists of a PTFE seal held between two backup plates. (See figure 1.2)

The seal is held outward against the walls of the stroking chamber by an o-ring and servo pressure which is fed into the center of the PTFE seal through slots in the backup plates and a small shuttle valve. Figure 1.3 shows an assembled stroking vane in the vane chamber.

Figure 1.2
 Stroking vane assembly

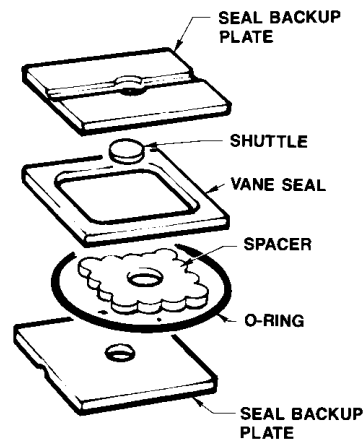

The stroking vanes and chambers are used on all pumps, one on either side. This duality increases the effective vane area and balances the rocker cam from side to side. It also allows the pump to be assembled with the control input on either side. Two arcuate shaped stroking chambers are bolted to either side of the rocker cradle (see figure 1.4). The centerline of the vane chamber arcuates is the same as the rocker cam center of rotation. The upper and lower vane chambers on one side (separated by the vane) are connected to the upper and lower vane chambers on the other side of the rocker cam by a pair of channels through the rocker cradle.

Figure 1.3
 Stroking vane installation

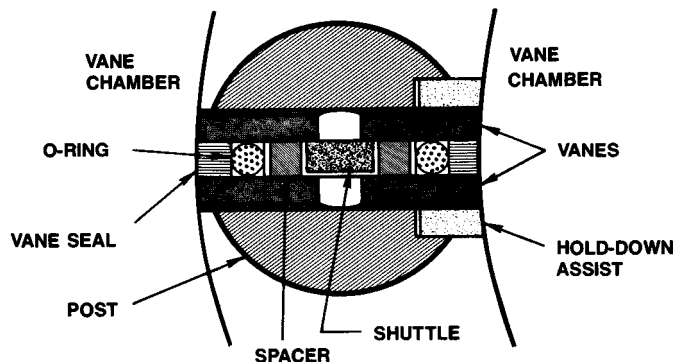
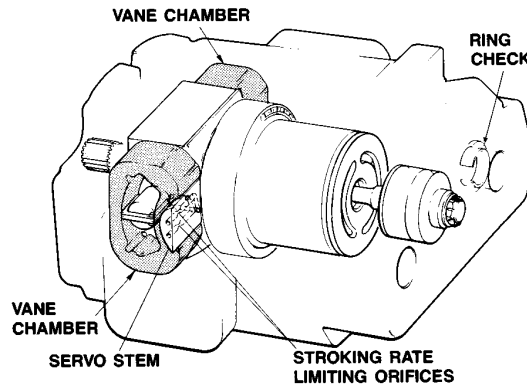
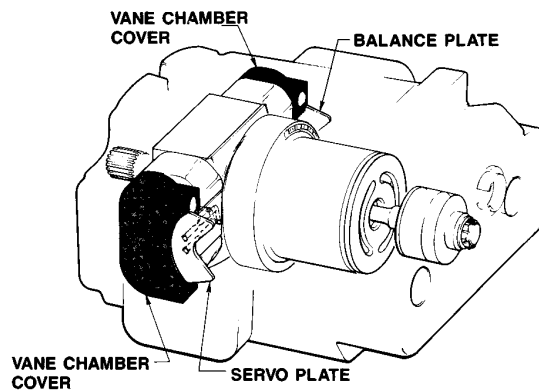

Figure 1.4
 GOLD CUP® pump internal
 configuration vane chambers and
 servo stems



Flow into the upper and lower vane chambers is carried in a pair of small channels drilled into the rocker cam (see Figure 1.1). Figure 1.4 shows the servo stems which are bolted to the rocker cam on both sides. Channels run through the length of the servo stem and depressions in the end of the stem connect the upper channel in the stem to the lower vane chambers and vice versa. Orifice plugs in the servo stem limit the flow rate into and out of the vane chambers and therefore the stroking rate.

Figure 1.5
 GOLD CUP® pump internal
 configuration vane chamber
 covers and servo plates



A flat servo plate is bolted to the servo stem on the control side of the pump and a flat balance plate is bolted to the servo stem on the output (displacement indicator) side of the pump (see Figure 1.5). The servo plate has two holes which connect directly to the channels in the servo stem while the balance plate is blank and plugs the end of its servo stem. Because the servo stems and plates are bolted to the rocker cam, they all move with the cam during displacement changes.

The vane chambers are sealed by covers which also form the fourth surface for the vane to seal against. In the covers are channels to carry the flow from the pressure compensator override tubes to the proper stroking vane chambers. The vane chamber cover on one side of the pump will port flow into one set of vane chambers (either upper or lower) while the cover on the opposite side ports flow into the other chambers. Figure 1.6 shows the vane chamber covers and the internal porting. Vane chamber cover porting will change with rotation as shown.

Figure 1.6
 Vane chamber covers

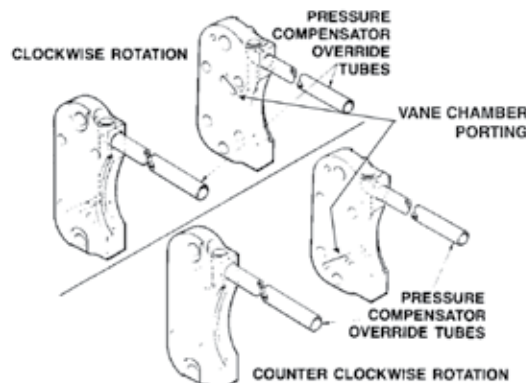

Figure 1.7
 GOLD CUP® pump internal
 configuration rotary servo input and
 displacement indicator

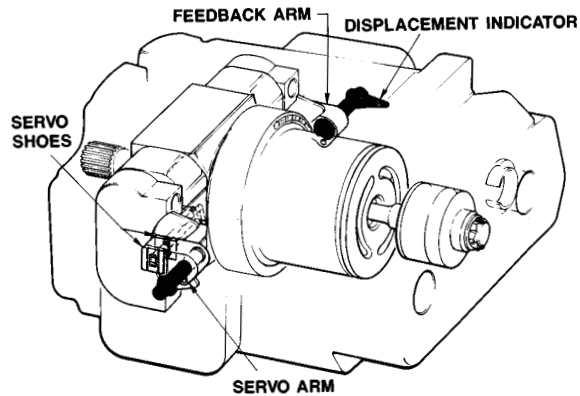
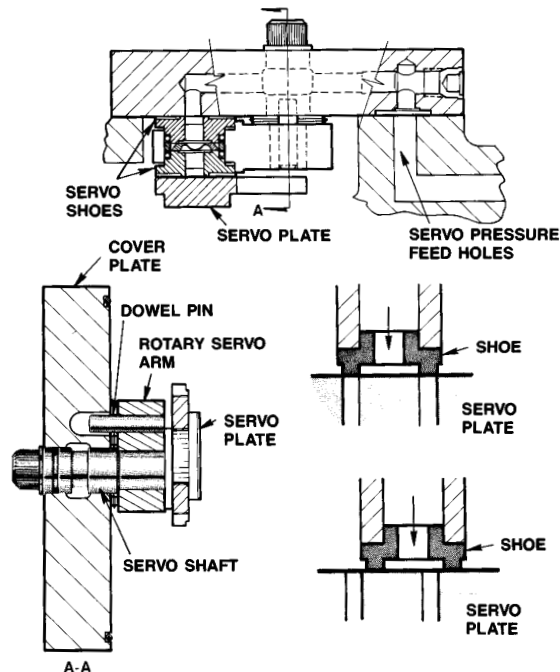

Figure 1.8
 Control cover - rotary servo input



Upward motion of the servo shoe with respect to the servo plate, opens the top hole of the servo plate to servo pressure and the bottom hole of the servo plate to case pressure. Servo pressure is then carried through the channels in the servo stem and rocker cam to the vane chamber below the vane actuator, while the upper vane chamber is opened to case pressure. The pressure differential establishes an upward force on the stroking vane and the rocker cam cradle rotates upward. The servo plate and stem traveling with the rocker cam also move upward until the holes in the servo plate are covered over by the lands on the servo shoe. With the holes covered up, there is no longer a pressure difference across the vane actuator and the rocker cam stops its rotation.

The servo shoe is configured such that it will store the full error signal. (i.e., rotary servo input at full displacement in one direction while the rocker cam is at full displacement in the other direction.)

There are four servo shoes in each pump. One shoe (inside shoe on the control side) provides the 4-way valve action, the outer shoe on the control side serves to feed servo pressure from the side plate to the inside shoe, while the other two shoes provide balancing forces to counteract loading on the servo link assemblies and rocker cam assembly. The servo link assembly on the control side is free to move and controls pump displacement. The servo link assembly on the other side of the pump is restrained by the heads of the socket head cap screws holding the servo stem and plate assembly to the rocker cam and therefore moves with the rocker cam during displacement changes. This side forms the displacement indicator.

Figure 1.9
Ring check assembly

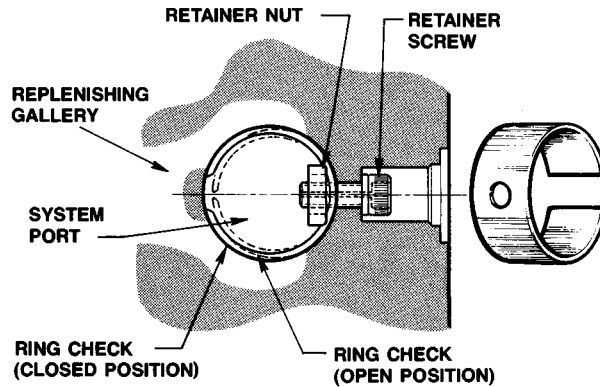

PACKAGE MOTOR CONFIGURATION

Figure 1.9 shows the ring checks which are used for replenishing check valves. The ring checks are located in the main ports (Figure 1.4). They consist of cylindrical shaped spring steel strips wrapped inside each system port and held in place by a retainer screw and nut. Large port areas at the ring check allow higher flow rates with small motions of the ring, thereby reducing bending and fatigue. Upon closing, a squeeze film between the ring and bore dampens the motion and prevents pounding. Both of these features are responsible for the high reliability and fast response of this check valve design.

The valve block assembly bolts to the top surface of the pump port block at the rear. This assembly holds the pressure compensator overrides valves, servo relief valve and replenishing relief valves and can be removed and replaced as an assembly. Its functions and the circuitry are described in the Circuitry Section 2.

GOLD CUP® hydrostatic transmission package motors are equipped with hot oil shuttle valves and low pressure replenishing relief valves as standard. They are available in both variable and fixed displacement versions.

All package motors use a rotating group of the same principle and design as the package pump. There are slight internal porting differences to enhance the motoring capabilities.

Figure 1.10
Fixed displacement motor

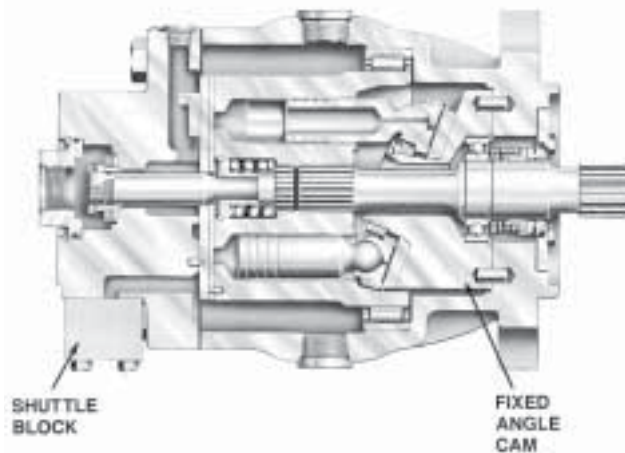

Fixed displacement motors (Figure 1.10) have a fixed-angle cam instead of a rocker and cradle assembly. There are no stroking mechanisms or controls.

Variable displacement motors use the same rocker cam, cradle and stroking mechanisms as the package pumps (see Figure 1.11).

Figure 1.11
Variable displacement motor

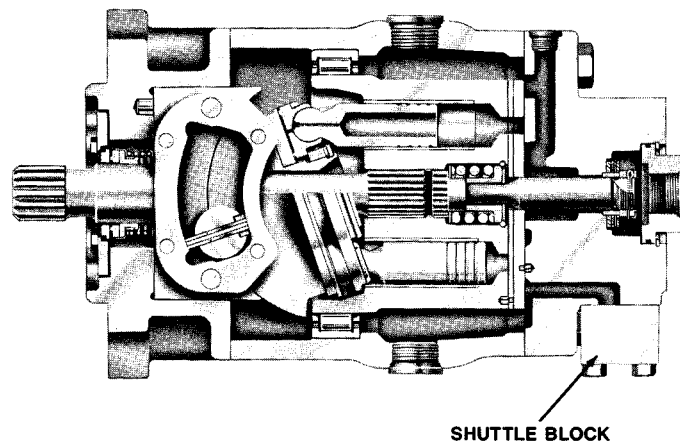

The gerotor pump(s), valve block and ring checks are not included. Since there is no gerotor, servo flow must be plumbed to the motor from an external source such as the pump servo pressure.

In place of the pump valve block, the package motors have a small valve block containing the hot oil shuttle and low pressure replenishing relief valve. Non-package motors do not have this block.

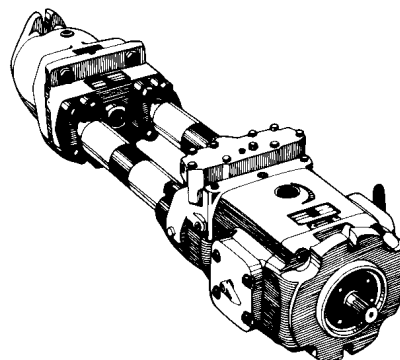

GOLD CUP® CIRCUITRY

GOLD CUP® series package pumps and motors contain within them all the circuitry normally required in a hydrostatic transmission. The pumps contain circuitry for the rotary servo actuator, servo pressure relief valve, replenishing relief valve, and pressure compensator override controls. Package motors contain the shuttle valve and low pressure replenishing relief valve.

PACKAGE PUMP CIRCUITRY

Figures 2.2, 2.3 and 2.4 show the circuitry contained in the GOLD CUP® pumps. The circuit in Figure 2.2 is for the 6.0, 7.25 and 8.0 in³/rev pumps. Figure 2.4 is the circuitry for the 24 and 30 in³/rev pumps. Figure 2.3 is the circuitry for the 11 and 14 in³/rev pumps, which contain a dual section servo and replenishing pump.

All the pumps in the GOLD CUP® line use the same valve block assembly, except that the 30 in³/rev valve block's servo pressure modulation pin is larger. It contains the pressure compensator override valving for both sides of the pump, the pressure modulated servo relief valve, replenishing relief valve and replenishing relief pilot stage. The circuitry contained in the valve blocks and the operation of the individual valves is the same for all pumps. Figure 2.1 shows the two types of poppets used in the valve block. The stepped poppet is a dual area poppet. The area on top of the poppet (A₁) is equal to twice the annular area (A₃) and twice the area of the underside of the poppet (A₂) (the underside area equals the annular area).

Figure 2.1
Poppets

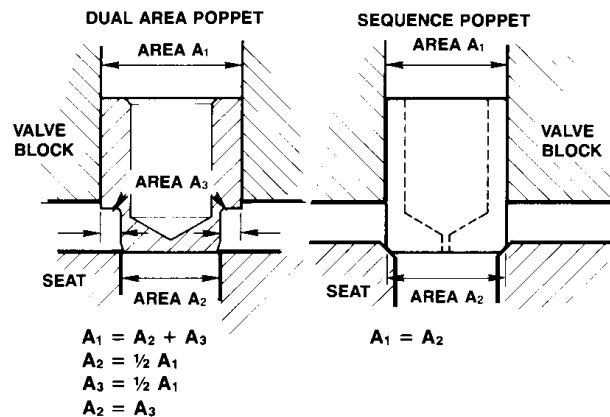

SERVO AND REPLENISHING CIRCUITS

The sequence poppet rests on a tapered seat and has only two important areas – the area above (A₁) and below the poppet (A₂). Since the poppet has straight sides and rests on a tapered seat, both areas are equal.

The sealing of the poppets is realized by floating seats to ensure optimal closure.

In circuits Figures 2.2, 2.3 & 2.4 the servo pressure oil flows from the servo-replenishing pump to the rotary servovalve. The servo-replenishing pump suction is shown in heavy blue and is drawn from a reservoir external to the pump. The rotary servovalve action was described in the Internal Configuration Section and will not be described here. The control flows from the servovalve are shown in dashed-blue and may be at a pressure less than servo pressure. Servo pressure is controlled by the pressure modulated servo relief valve in the valve block.

Output flow from the servo-replenishing pump is exposed to the annular area of the servo relief valve poppet and after the force created by pressure on the annular area exceeds the spring force plus the force provided by the pin and replenishment pressure on the top of the poppet, the poppet will lift and allow flow into the replenishing gallery (green lines). All other areas of the pressure modulated servo relief valve are exposed to replenishing pressure, as shown in green. This exposes to replenishing pressure a net area difference on top of the poppet equal to the area exposed to servo pressure. This makes the pressure modulated servo relief valve sensitive to replenishing pressure. The pressure setting of this relief valve is therefore equal to the spring force plus the force generated by the pin on top of the poppet plus replenishing pressure. Minimum servo pressure is approximately twice replenish and increases 40 psi, 2,76 bar per 1000 psi, 69 bar as system pressure increases due to the modulating pin.

(For the 30 series, servo pressure increases 62 psi, 4,14 bar per 1000 psi, 69 bar.) In the 6.0, 7.25 and 8 in³/rev pumps (Figure 2.2), the servo pressure gallery is threaded to receive a plug which is supplied with each pump. If the plug is not used, servo flow is free to travel directly from the servo-replenishing pump to the servo relief valve.

With the plug installed as shown in Figure 2.2, servo flow must be externally plumbed between the two filter ports. This allows filtering of the servo oil before it reaches the replenishing gallery. Consult installation drawings or sales bulletins for port locations. However, not all of the servo oil is filtered. Servo oil flowing to the rotary servo on the “B” port side is not filtered. If the rotary servo control is on the “A” port side, servo flow to the rotary servo is filtered.

In the 24 and 30 in³/rev pumps (Figure 2.4), servo pump output is directed to port G, where a customer supplied filter, filters all servo oil. Excess servo oil spills over the servo relief valve and into the replenishing gallery.

In the 11 and 14 in³/rev pumps (Figure 2.3), the servo pressure oil is not filtered. In these pumps, the oil is filtered at replenishing pressure.

Replenishing flow is supplied by both the servo pump and replenishing pump. Excess servo flow from the servo pump spills over the servo relief valve and into the replenishing gallery where it joins the flow from the replenishing pump. The combined flow from the two sources is then fed to the replenishing checks and the replenishing relief. If the optional plug is inserted into the replenishing gallery it blocks the flow before it reaches the replenishing checks. When the plug is installed, the replenishing flow **must** be externally plumbed. See installation drawings or the sales bulletins for port locations.

Replenishing pressure in all pumps is controlled by the replenishing relief valve, which is in turn controlled by the replenishing relief pilot stage. Replenishing pressure is exposed to the annular area of the replenishing relief valve as shown. When replenishing pressure exceeds the pressure set into the relief pilot stage, the pilot opens, allowing a flow from the top of the replenishing relief valve which creates a pressure drop created through the orifice leading to the top of the valve from the replenishing gallery. The valve then opens and controls the pressure in the replenishing gallery. A small filter screen between the replenishing relief poppet and pilot section prevents the pilot from becoming stuck from contamination. Excess replenishing flow is spilled into the light blue area and is carried through a passage near the port plate in the port block before it spills into the case of the pump. This flow cools the port plate to cylinder barrel interface during idle. Internal leakage from the rotating group and output control flow from the manual rotary servo, join the excess replenishing flow in the case and all are carried out the case drain.

If it becomes necessary to provide additional replenishing flow, an auxiliary replenishing port is available at the rear of the pump for this purpose. See installation drawings or sales literature for its location. These ports are standard on all GOLD CUP® pumps.

The replenishing relief valve is a dual area valve. Replenishing pressure is exposed to the annular area of the replenishing poppet and to the area on top of the poppet. This creates an unbalanced area exposed to replenishing pressure on top of the poppet equal to the area exposed to case pressure under the poppet. Replenishing pressure is therefore sensitive to case pressure. Should the force of the case pressure exceed the force of the replenishing pressure and spring on the replenishing relief valve, the replenishing relief valve will open and allow backflow from the case of the pump into the replenishing gallery. This is called case pressure replenishing. Its use is explained in the application notes Section 4.

PRESSURE COMPENSATOR OVERRIDE

In both circuits the area shown in red is the high pressure work port and the area shown in green is the low pressure work port. In the high pressure port, high pressure is exposed to the blocked side of the replenishing check valves, the blocked side of the small check valves going to the top of the dual level relief valves in the compensator circuit, and to the underside of the sequence valves in the pressure compensator circuit. When the pressure in the work port exceeds the setting of the pressure compensator override pilot section, the pilot section will open, allowing flow into the replenishing gallery. This small flow creates a pressure drop across the orifice in the bottom of the high pressure sequence valve, and the valve opens. This allows oil to flow into the override tube which carries it to the appropriate vane chamber. This pressure overrides the manual rotary servo control pressure and changes the pump displacement.

The sequence valve has equal areas above and below the poppet. Secondary port pressures are not exposed to any unbalanced areas of the poppet and therefore the sequence valve setting is independent of downstream pressure.

The pressure in the override tube is limited by the dual level relief valve which has servo pressure on its top area. The annular area is half of the area on top of the dual relief valve, therefore the pressure in the override tube is limited to twice servo pressure plus the spring force. Excess flow which is not used to change the stroke of the pump is ported directly into the replenishing gallery through this valve.

During compensation the flow leaving the opposite vane chamber exits through the opposite override tube and goes across the dual level relief valve on the low pressure side of the pump. This valve is set to a lower pressure than the opposite valve, due to the orifices on either side of the top area. Oil, initially at servo pressure, flows through the equal size orifices which drop the pressure on top of the poppet to half servo pressure before it exits through the small check valve into the low pressure work port. Since the annular area is equal to half the area on top of the dual level relief valve, and the pressure on top of the dual level relief valve is half servo pressure, the pressure setting of the annular area of the dual level relief valve is equal to servo pressure plus the spring force. This creates a maximum pressure difference across the vane actuators, during pressure compensating, approximately equal to servo pressure. Override pressure must be higher than servo pressure in order to move the rocker cam.

The pilot section of the pressure compensator override circuit consists of a spring loaded cone and seat and two isolation check valves. The isolation check valves prevent the low pressure side of the circuit from affecting the high pressure setting and also allow individual vents or remote controls to be connected to either side of the pressure compensator override. There is also a common vent connection which can control both sides of the override. The pressure compensator override pilot control is externally adjustable. Please consult installation drawing for its location on the pumps.

Pressure compensator override pilot pressure is exposed to the top of the pin which pushes on the pressure modulated servo valve. This makes the servo pressure setting dependent upon the pressure in the high pressure work port. Since lower control forces are required for low system pressures, it is possible to reduce the servo pressure without loss of control. This also reduces parasitic horsepower losses from the servo and replenishing pump. Servo pressure increases approximately 40 psi for every 1000 psi, 4 bar for 100 bar of system pressure. (For the 30 series, servo pressure increases 62 psi, 4,14 bar per 1000 psi, 69 bar.)

When system pressure drops below the pressure compensator override setting, the manual rotary servo control, which is still displaced to the original setting, takes over control of the pump and the pump strokes back to its original setting at a rate controlled by the orifices in the servo stem.

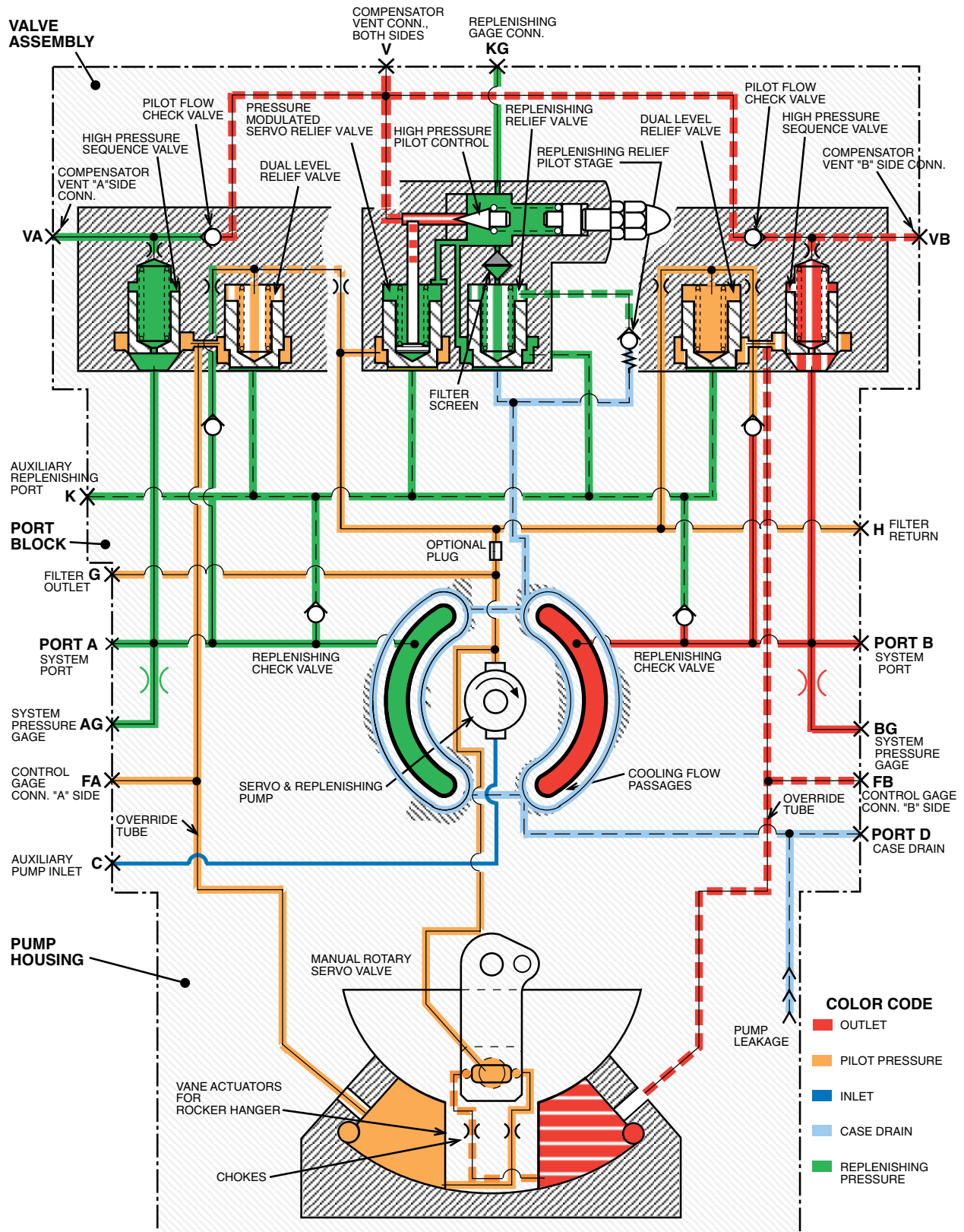

Figure 2.2
6.0, 7.25 and 8.0 in³/rev Pump circuit

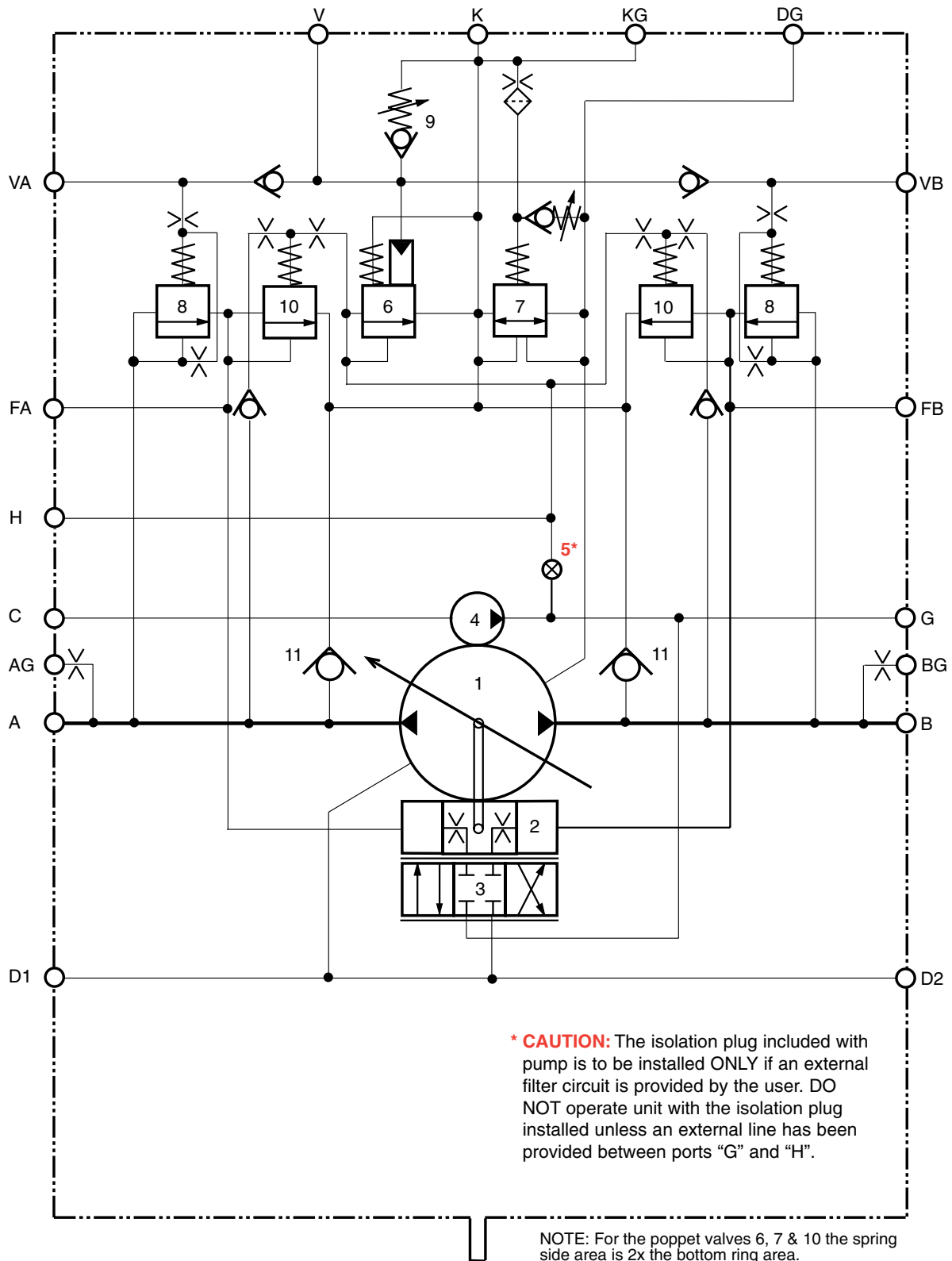

Figure 2.2.1
6.0, 7.25 and 8.0 in³/rev Pump circuit
(ISO Standard)

NOMENCLATURE

(For ISO circuit Figure 2.2.1)

<u>ITEM</u>	<u>DESCRIPTION</u>
1	Piston pump
2	Vane chambers
3	Rotary servo
4	Servo and replenishing pump
5	Plug optional
6	Servo relief valve (modulated by operating pressure)
7	Replenishing relief valve
8	High pressure sequence valve (2)
9	High pressure pilot control
10	Dual level relief valve (2)
11	Replenishing check valve

<u>PORT CODE</u>	<u>CONNECTION FUNCTION</u>	<u>PORT SIZE OR THREAD</u>
A,B	System power	4-bolt pad for SAE-1.5" 6000 psi, 414 bar
A	Open loop inlet	4-bolt pad for SAE-2" 3000 psi, 207 bar
AG,BG	System pressure gage, each side	SAE-6 straight thread
C	Auxiliary pump inlet	SAE-16 straight thread
DG	Case pressure gage	SAE-6 straight thread
D1,D2	Case drains	SAE-12 straight thread
G	Auxiliary pump outlet	SAE-8 straight thread
H	Auxiliary flow return	SAE-8 straight thread servo pressure
K	Replenishment inlet	SAE-16 straight thread
KG	Replenishing pressure gage	SAE-6 straight thread
FA	Control area, A side	1/4" NPTF Dryseal
FB	Control area, B side	1/4" NPTF Dryseal
V	Compensator vent, both sides	SAE-4 straight thread
VA	Compensator vent, A side	SAE-4 straight thread
VB	Compensator vent, B side	SAE-4 straight thread

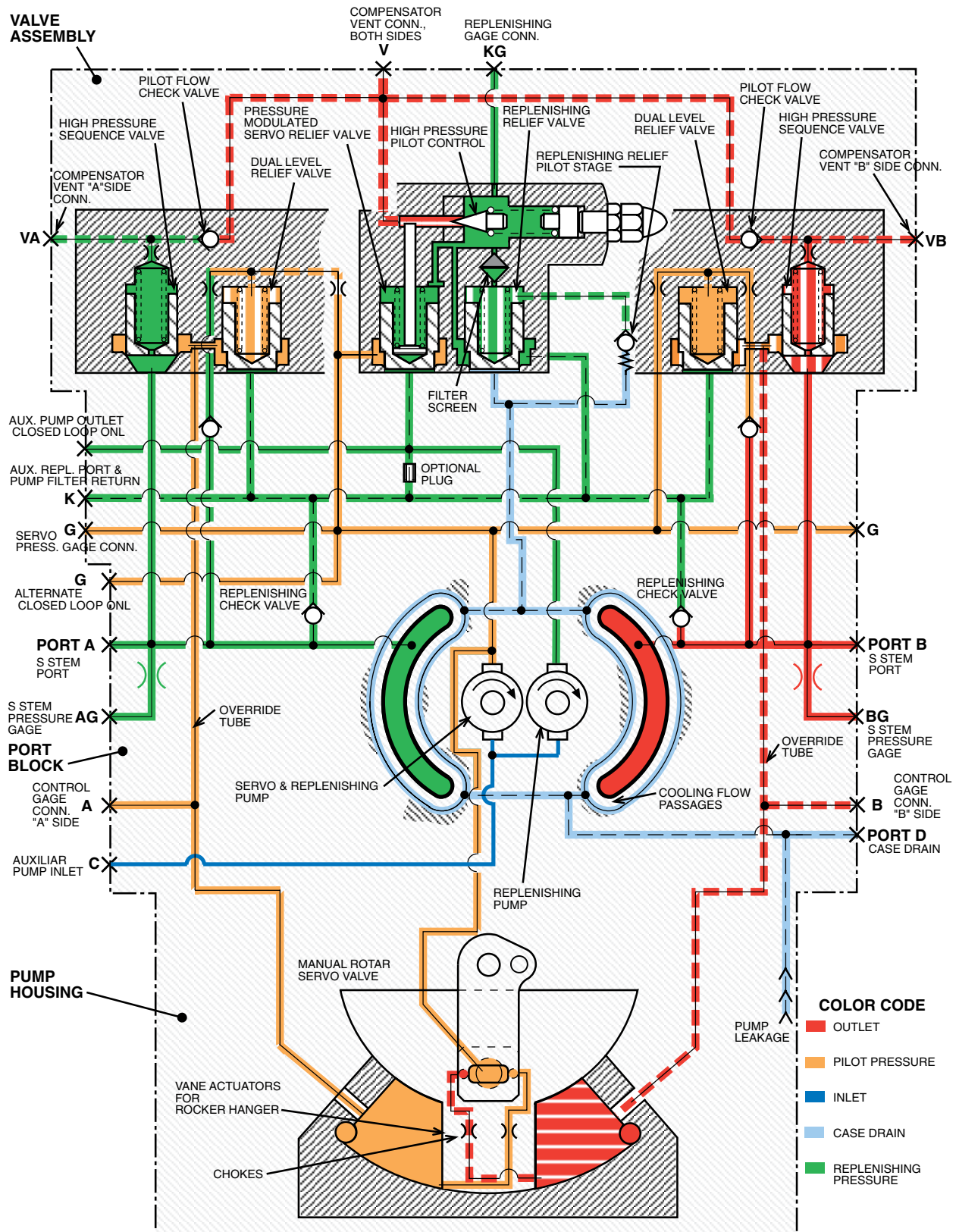

Figure 2.3
11 and 14 in³/rev Pump circuit

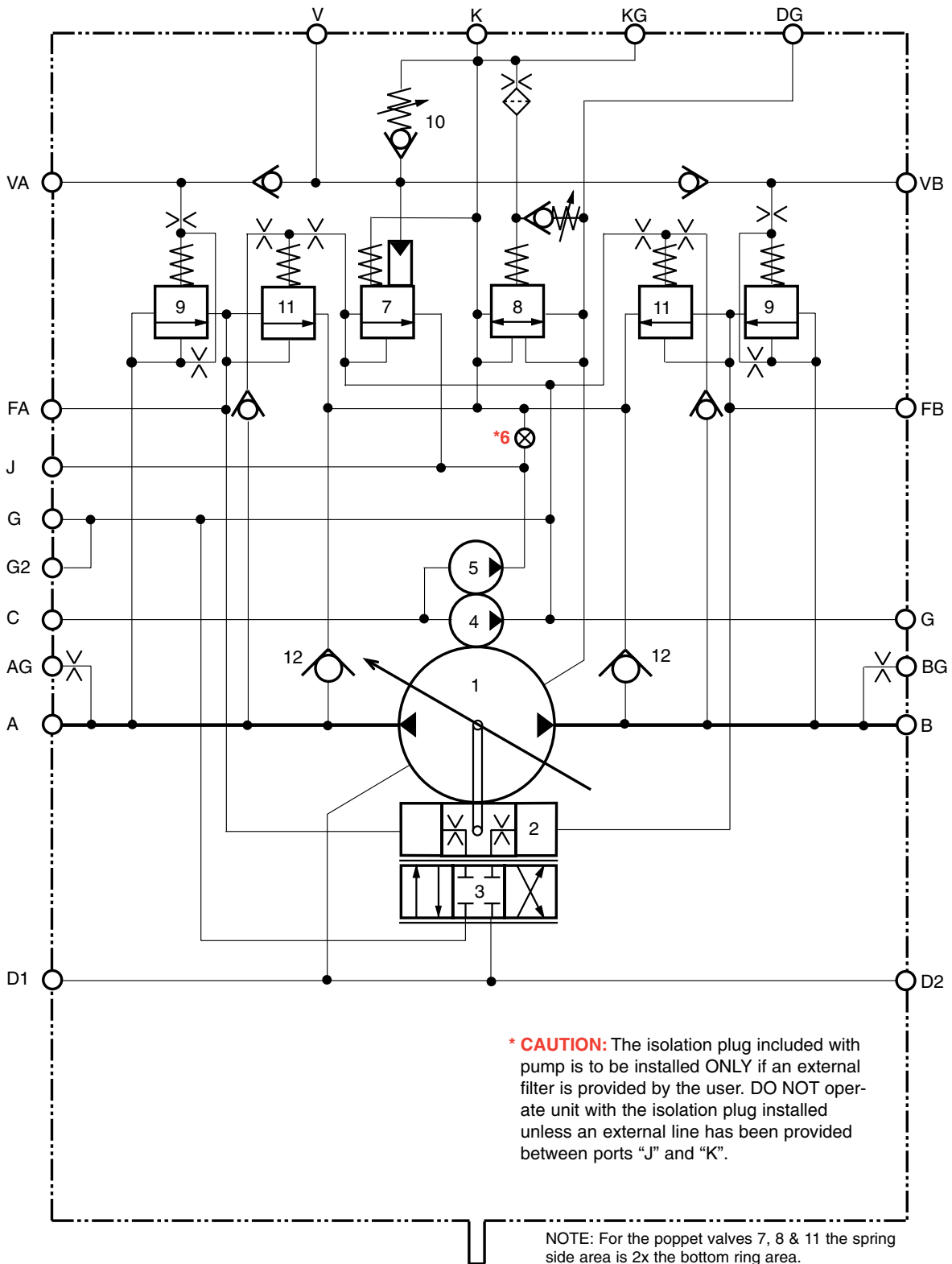

Figure 2.3.1
 11 and 14 in³/rev Pump circuit
 (ISO Standards)

NOMENCLATURE

(For ISO circuit Figure 2.3.1)

<u>ITEM</u>	<u>DESCRIPTION</u>
1	Piston pump
2	Vane chambers
3	Rotary servo
4	Servo pump
5	Replenishing pump
6	Plug (optional)
7	Servo relief valve (modulated by operating pressure)
8	Replenishing relief valve
9	High pressure sequence valve (2)
10	High pressure pilot control
11	Dual level relief valve (2)
12	Replenishing check valve

<u>PORT CODE</u>	<u>CONNECTION FUNCTION</u>	<u>PORT SIZE OR THREAD</u>
A,B	System power	4-bolt pad for SAE-1.5" 6000 psi, 414 bar
AG,BG	System pressure gage, each side	SAE-6 straight thread
C	Auxiliary pump inlet	SAE-20 straight thread
DG	Case pressure gage	SAE-6 straight thread
D1,D2	Case drains	SAE-16 straight thread
G	Servo press. gage conn. each side	SAE-4 straight thread
G2	Alternate (closed loop only)	SAE-8 straight thread
K	Auxiliary Replen. pressure return port	SAE-16 straight thread port & pump filter
J	Aux. pump outlet (closed loop only)	SAE-10 straight thread
KG	Replenishing pressure gage	SAE-6 straight thread
FA	Control pressure gage, A side	SAE-6 straight thread
FB	Control pressure gage, B side	SAE-6 straight thread
V	Compensator vent, both sides	SAE-4 straight thread
VA	Compensator vent, A side	SAE-4 straight thread
VB	Compensator vent, B side	SAE-4 straight thread

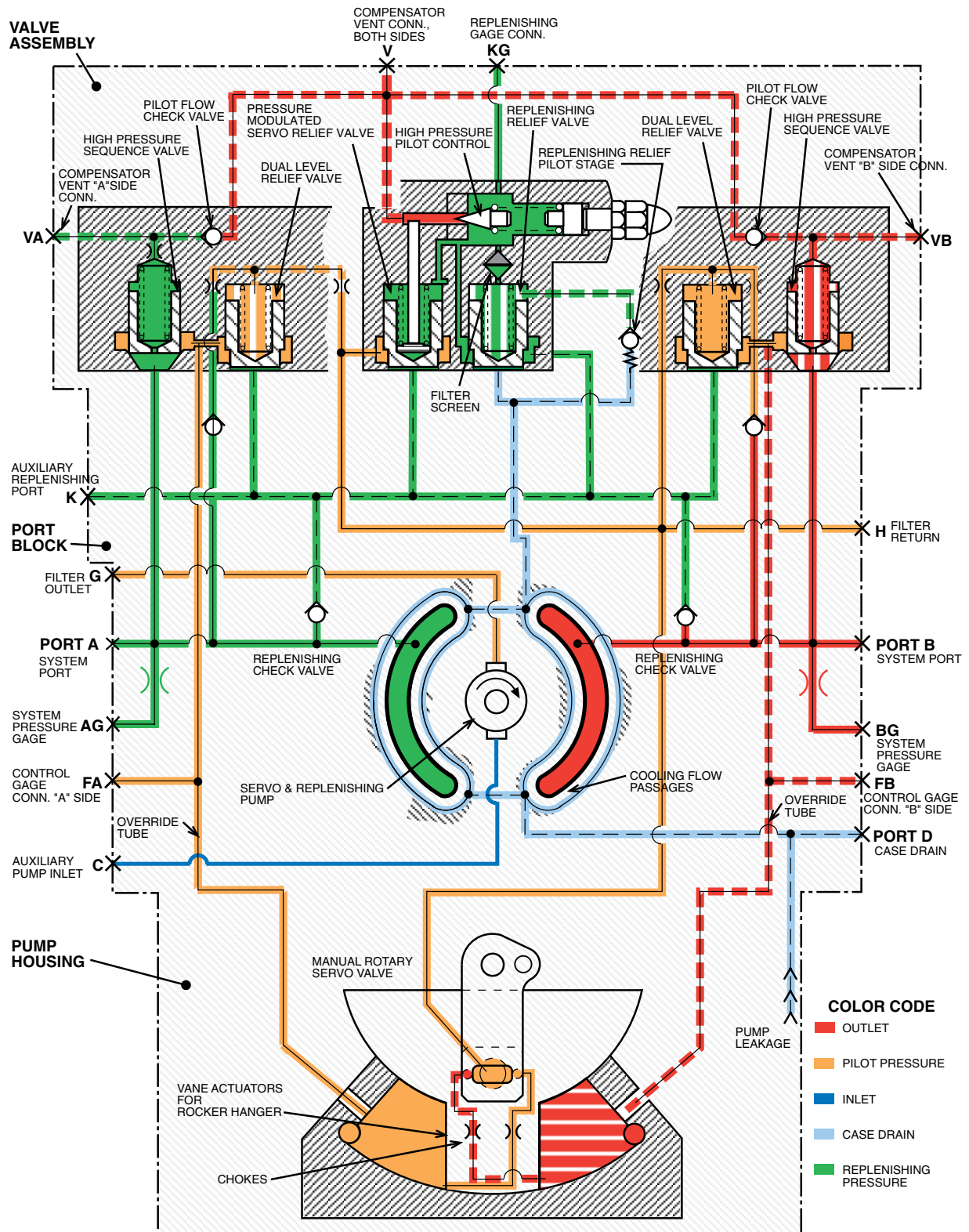

Figure 2.4
24 and 30 in³/rev Pump circuit

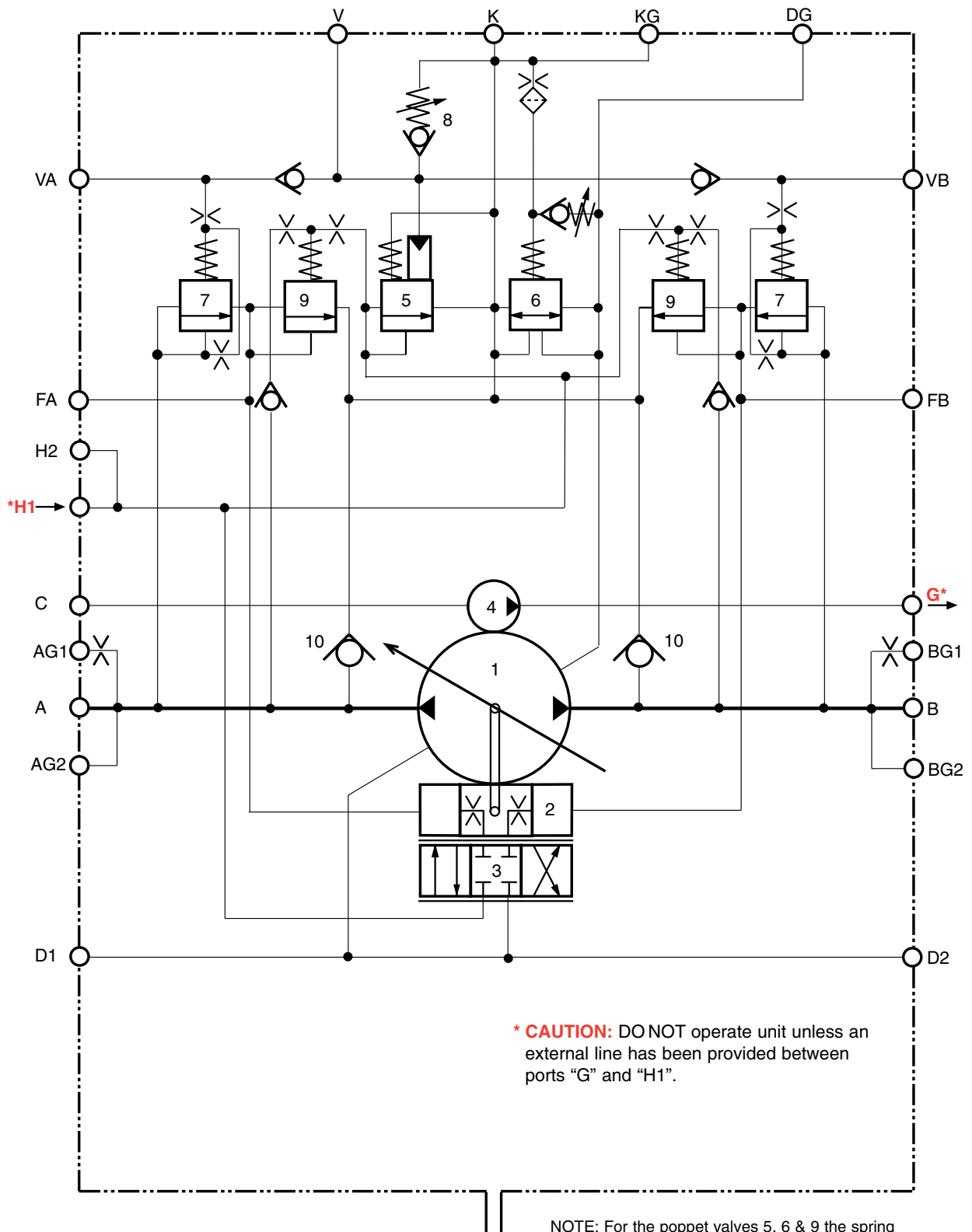

Figure 2.4.1
24 and 30 in³/rev Pump circuit
(ISO Standard)

NOTE: For the poppet valves 5, 6 & 9 the spring side area is 2x the bottom ring area.

NOMENCLATURE

(For ISO circuit Figure 2.4.1)

<u>ITEM</u>	<u>DESCRIPTION</u>		
1	Piston pump		
2	Vane chambers		
3	Rotary servo		
4	Servo and replenishing pump		
5	Servo relief valve (modulated by operating pressure)		
6	Replenishing relief valve		
7	High pressure sequence valve		
8	High pressure pilot control		
9	Dual level relief valve (2)		
10	Replenishing check valve (2)		
		<u>PORT CODE</u>	<u>CONNECTION FUNCTION</u>
			<u>PORT SIZE OR THREAD</u>
		AG1,AG2 (A-side)	System gage AG1 SAE-6 straight thread AG2 SAE-8 straight thread
		BG1,BG2 (B-side)	System gage BG1 SAE-6 straight thread BG2 SAE-8 straight thread
		C	Auxiliary pumpsupply inlet (Servo & Replen.) 2" SAE 3000 psi 4-bolt flange
		DG	Case pressure gage SAE-6 straight thread
		D1,D2	Case drains SAE-20 straight thread
		G	Aux. pump (Servo & Replen.) SAE-12 straight thread Outlet to ext. filter
		H1	Servo and Replenish SAE-12 straight thread Inlet from servo filter
		H2	Servo gage SAE-6 straight thread
		K	Optional-Replenishing SAE-32 straight thread Pump supply inlet
		KG	Replenishing pressure gage SAE-6 straight thread
		FA	Control pressure gage, A side SAE-6 straight thread
		FB	Control pressure gage, B side SAE-6 straight thread
		V	Compensator vent, both sides SAE-4 straight thread
		VA	Compensator vent, A side SAE-4 straight thread
		VB	Compensator vent, B side SAE-4 straight thread

The circuitry provided in the GOLD CUP® hydrostatic pumps provides some special features not found in other transmissions pumps.

1. The servo pressure in the GOLD CUP® line varies with system pressure without reducing control ability. This gives a higher efficiency with a corresponding reduced heat load to the circuit.
2. There is no need for cross port relief valves external to the pump. The relief sequence valve circuit in the pressure compensator override circuit accomplishes this function. Should the pump not be able to continue to change its stroke for any reason, flow from the high pressure work port will go across the high pressure sequence valve, across the dual level relief valve and into the replenishing gallery where it is carried to the opposite work port.
3. All excess flows from the control valves, with the exception of the rotary servo, are directed into the replenishing gallery. This prevents momentary loss of replenishing pressure when the pump is responding to controls.
4. It is possible to prevent momentary cavitation in the pump, at low shaft speed and high pressure, by connecting case drains from the motor and pump together and passing them through a 40 psi (2.8 bar) check valve before plumbing to the reservoir. This insures that should there not be sufficient replenishing flow, the case drain leakages are available for replenishing. This is due to the replenishing relief valve's capability of accepting flow from the case drain into the replenishing gallery, if there is sufficient pressure in the case.

PACKAGE MOTOR CIRCUITRY

Package motors contain the shuttle valve and the low pressure replenishing relief valve. The circuitry contained in the motor is shown in Figure 2.5. The shuttle spool is shifted to one side by system pressure. When shifted the low pressure side of the loop is connected to the primary side of the low pressure replenishing relief valve. The low pressure replenishing relief valve is set to a lower pressure than the replenishing relief valve in the pump. This insures that all the available replenishing flow enters the circuit for cooling. Optional orifices may be installed in the shuttle-relief block to limit the flow through the shuttle. With the orifices, flow through the shuttle is limited and the shift is very positive.

Figure 2.5
GOLD CUP® package motor circuit

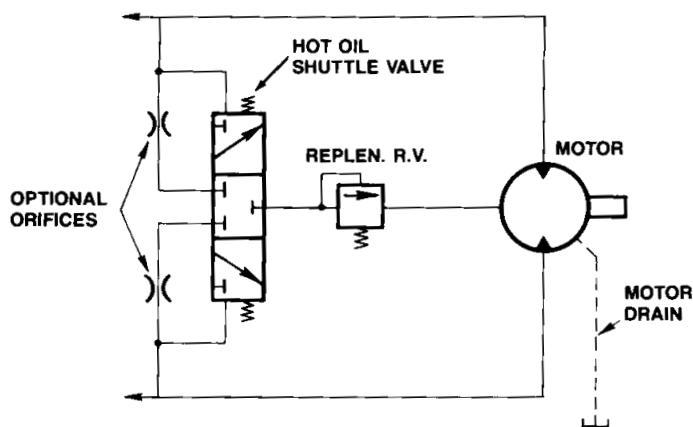

GOLD CUP® CONTROLS

The spring centered rotary servo input, pressure compensator override, and displacement indicator are all standard features on all GOLD CUP® package pumps. Spring centering is used in addition to the rotary servo input control to provide a positive return-to-neutral action. It includes an adjustable neutral position to allow fine tuning the neutral position, or offsetting the neutral position. Variable motors have spring offset rotary servo inputs, cylinder controls and displacement indicators as standard features. Additional, optional controls are available which increase the utility of the GOLD CUP® components. These controls include the following:

- Adjustable displacement stops
- Manual screw adjustment
- Automatic brake and neutral bypass control
- Torque limit override
- Hydraulic stroker
- Electrohydraulic stroker
- Electrohydraulic servo
- Cylinder control
- Electrohydraulic cylinder control

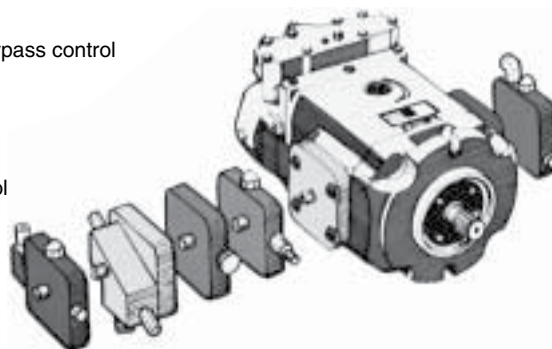

Adjustable displacement stops

Adjustable stops are available as an option. They provide an adjustment to limit the maximum displacement of the rotary servo input between zero and full displacement on both sides of center.

Manual screw adjustment

A manual screw adjustment is available to provide an easily set pump displacement which will not move during operation. It is used when pump displacement will be adjusted infrequently.

Automatic brake and neutral bypass control

The automatic brake and neutral bypass control is used to actuate a spring set pressure released parking brake and open a small channel between the system ports when the rotary servo input and rocker cam are coincident in the neutral position. If one or the other device is not in the neutral position, the control will not shift into the brake and bypass mode. This control is used on track drives, swing drives, hoist drives and any other system where creeping is intolerable. In some cases this control may be used for the bypass function alone.

Torque limiter override control

The torque limit override control is used for limiting the input shaft torque. At constant speeds it serves as a horsepower limit override. This control maintains a relationship between displacement and pressure which results in a limitation of the input torque. At torque levels below the set value the pump follows the input rotary servo normally, but if pressure or displacement (or both) increase to a value which results in torque higher than set by the control, the pump will destroke to limit the input torque. Because this control works with displacement instead of flow, the horsepower setting varies directly with shaft speed.

Hydraulic stroker

The hydraulic stroker is used on both pump and motors. This control positions the rotary servo proportionally to externally controlled pilot pressure.

Electrohydraulic stroker

The electrohydraulic stroker is used on both pumps and motors. It provides an input rotary servo position proportional to input current. It is used primarily with remote electrical controllers. It may be used with programmed controllers as long as the system does not require rapid response. Presently, there are two versions available, the 500 and 900 series.

Electrohydraulic servo

The electrohydraulic servo provides a control for electrohydraulic systems requiring rapid response and precise control. RVDV feedback or Potentiometer feedback are available options.

Three position cylinder control

The three position cylinder control permits a pump to be offset to an adjustable displacement on either side of center by supplying a pilot signal to the appropriate control port. With no signal the pump returns to an adjustable zero stroke position.

Two position cylinder control

The two position pump cylinder control permits a pump to be offset to an adjustable displacement on one side of center by supplying a pilot signal to the appropriate control port. With no signal the pump returns to an adjustable zero position.

The two position motor cylinder control permits a motor to be stroked to a reduced displacement by supplying a pilot signal to the appropriate control port. With no signal the motor returns to an adjustable maximum stroke position.

Two and three position cylinder control with integrally mounted electric directional control valve

By mounting an electric directional control valve on the cylinder control, the pump or motor stroke may be controlled by energizing the appropriate solenoid valve, eliminating the need for separate mounting and fluid connections to the control valve.

The following sections detail the operation of the controls described above.

ROTARY SERVO INPUT

The internal configuration section of this manual describes in detail the hydraulic operation of the rotary servo input control. Mechanically the rotary servo control is an arm and shaft assembly carried in a bore in the control cover (see Figure 3.1).

Figure 3.1
Control cover - rotary servo input

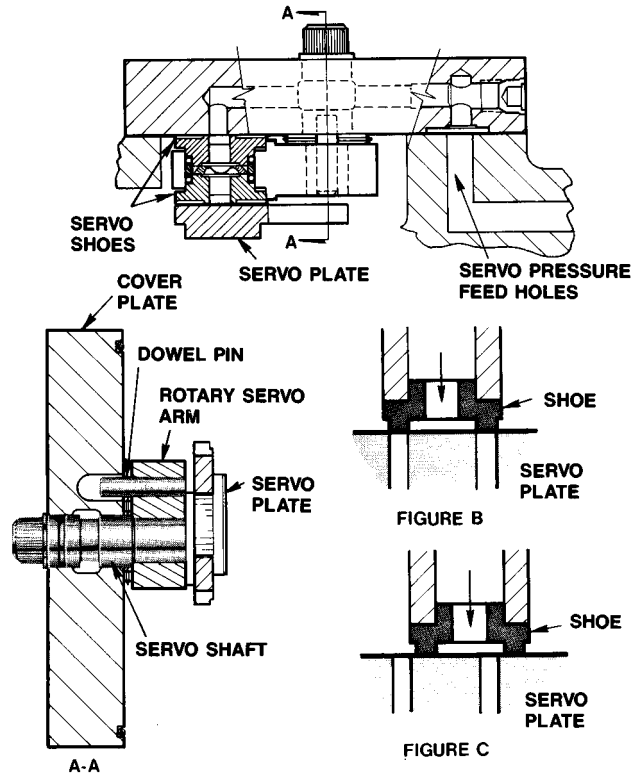

Carried in the arm are a pair of shoes, one of which, (servo shoe) acts as a 4-way shear seal valve in conjunction with the servo plate. The other, (balance shoe) bears against the control cover and balances the force loads on the arm created by servo pressure acting on the servo shoe. Both shoes are sealed with o-rings and are held against the control cover and servo plate by a spring washer. A dowel pin is pressed into the arm and extends into a slot in the control cover.

Servo pressure is fed into the control cover through a port in the pump case. It is carried through a channel, around the rotary servo input shaft, then to a port through which the pressure is fed to the servo shoes. Servo pressure feeds through the center of both shoes and bears against the servo plate and control cover. Servo pressure is available to the shoes on both the rotary servo input arm and the displacement indicator arm for balance and to allow mounting the control input on either side of the pump.

Servo pressure partially floats the servo shoes and reduces friction so the basic rotary servo control without spring centering only requires 2 lbs-in. (0.23 Nm) torque to rotate. The servo rotates through an arc of $\pm 19^\circ$ from zero to full displacement in both directions, and is designed to accept the full error signal of 38° (pump at full displacement one direction, input full displacement in the other direction). Motion of the input servo arm is stopped at full displacement by roll pins pressed into the control cover. On the input side of the pump the rotary servo shaft is left bare while a pointer is pressed onto the indicator shaft on the output side.

The pump is capable of having the rotary servo input on either side, but it is necessary to change the control covers, servo stems, servo plate and the balance plate. These parts may be transferred from side to side on the pump and do not need to be exchanged for other parts. It may be necessary to disassemble and rearrange the contents of the control cover to allow it to function correctly.

Since the rocker cam rotates to follow the rotation of the rotary servo input shaft, the phasing between rotary servo input rotation and input and output ports of the main pump will vary with input side and pump shaft rotation. This information is supplied with each pump on a tag with the chart shown below:

ROTATION	CONTROL		FLOW	
	Main shaft	Mtg. position	input rot.	Port A Port B
R	A	C. W.	IN	OUT
L	B	C. C. W.	OUT	IN
R	B	C. W.	OUT	IN
L	A	C. C. W.	IN	OUT

SPRING CENTERED ROTARY SERVO

(4** control)

Figure 3.2
Spring centered rotary servo
(zero stroke)

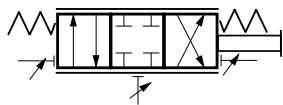

The spring centered rotary servo control provides a centering torque to the rotary servo of 13-20 lbs-in. (1.5-2.3 Nm) and provides an adjustable center position with a range of ±5%. (see Figure 3.2)

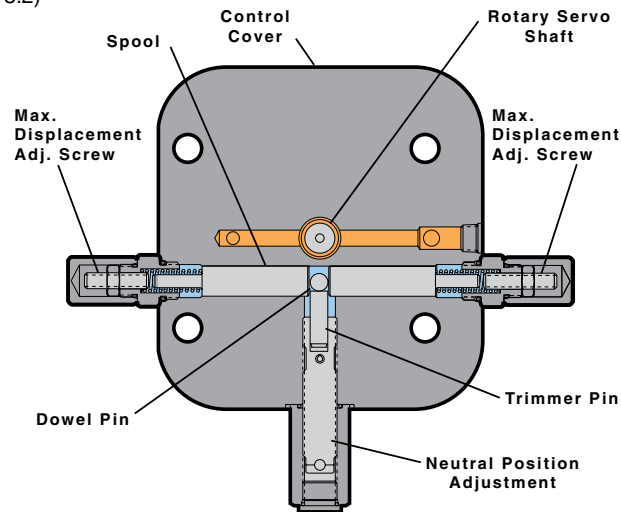

A pair of spring loaded spools bear against the dowel pin in the rotary servo arm and push the dowel pin toward the neutral position from both directions of travel. They are stopped by the neutral trimmer pin in the center position adjustment. When the rotary servo is moved off the neutral position (see Figure 3.3), the servo arm dowel pin pushes one spool with it. The other spool is prevented from moving by the pin in the neutral trimmer adjustment. Neutral position is set by the off-center dowel pin in the adjuster. When the adjuster is rotated, the pin moves axially to the centerline of the spring loaded spools and varies the neutral position.

Figure 3.3
Spring centered rotary servo
(on stroke)

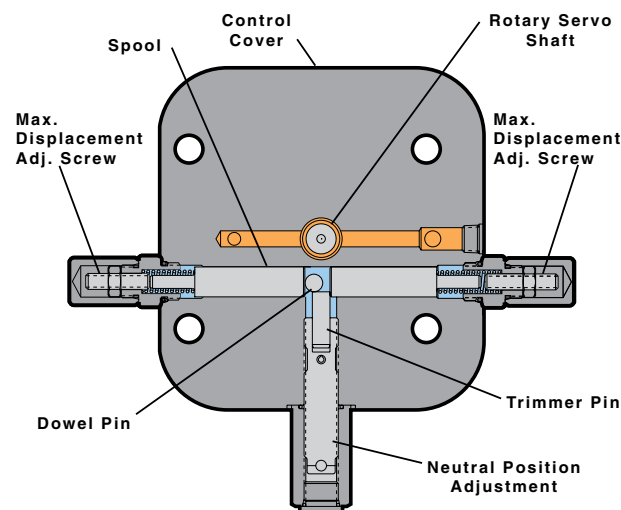

ADJUSTABLE STOPS

Control Option A

Adjustable stops are available as an option on the spring centered rotary servo with and without automatic brake and bypass valve. Adjustable stops are standard on all other controls.

The relationship between number of turns (T) of the adjusting screws and pump or motor stroke is:

Manual screw adjustment.....	6.72 turns full to zero
Motor cylinder control	4.7 turns full to 30% stroke
Three position cylinder control	6.72 turns full to zero
Spring centered rotary servo.....	6.72 turns full to zero
Hydraulic stroker (800 series)	5.04 turns full to zero
(for motors)	3.5 turns full to 30% stroke
Electrohydraulic stroker (500 series).....	8.5 turns full to zero
(for motors)	6 turns full to 30% stroke
Electrohydraulic stroker (900 series).....	5.04 turns full to zero
(for motors)	3.5 turns full to 30% stroke

MANUAL SCREW ADJUSTMENT

(1** control)

The manual screw adjustment control is available as an option to allow the pump displacement to be set and left at that setting. It can also serve as the maximum volume adjustment when the pump is used as a pressure compensator pump. In this control, the dowel pin in the rotary servo arm is pushed to maximum displacement by the spring pushing on the spool (see Figure 3.4).

Figure 3.4
 Manual screw adjustment

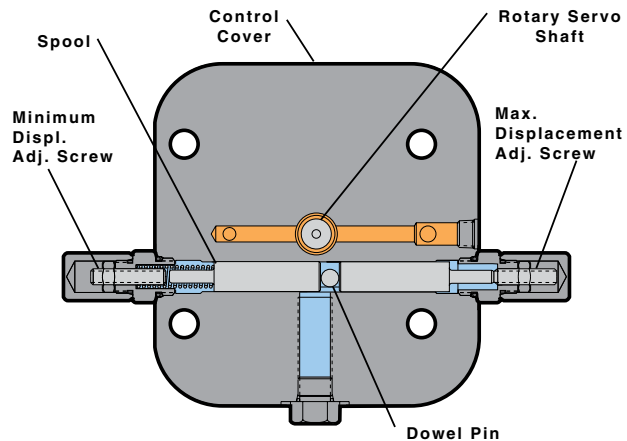
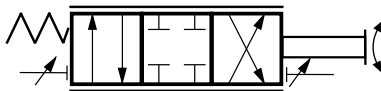

The maximum displacement screw limits the maximum volume to which the rotary servo is pushed and is adjustable from full to zero displacement. An adjustable minimum stop is located on the opposite side of the control cover and is adjustable from zero to 50% of max. full stroke. During operation the rotary servo may be manually destroyed off of the manual screw stop by a torque of 20 lbs-in., 2.3 Nm on the rotary servo input shaft.

The relationship between the number of turns of the manual screw and stroke is the same as given in the adjustable stop description above.

MOTOR CYLINDER CONTROL

(2A* control)

The motor cylinder control consists of two spools in the bore in the input control cover, one longer than the other. This limits stroke to one side of center, 30% stroke to full stroke. (see Figure 3.5) This control is spring offset to maximum displacement.

Figure 3.5
 Motor cylinder control (max.stroke)

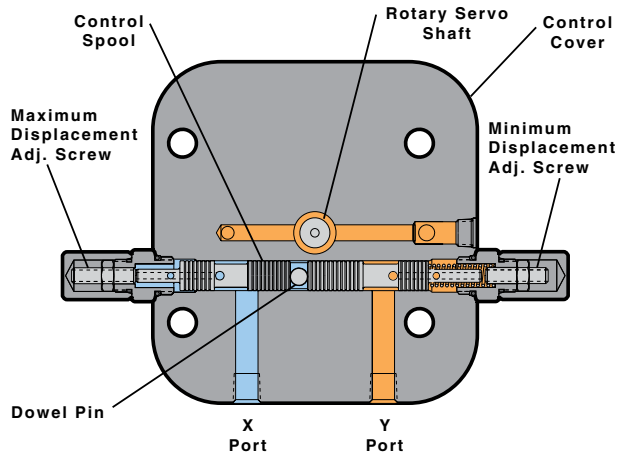
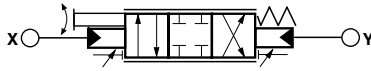

Applying pressure to port X puts pressure through the channel in the spool to the left and into the cavity behind it. The force generated pushes the rotary servo pin against the spring bearing against the opposite spool and the rotary servo moves to minimum stroke (see Figure 3.6). A minimum of 300 psi, 20.7 bar differential across the two ports is required for positive action.

Figure 3.6
 Motor cylinder control (Min. stroke)

When pressure is applied to port Y it is carried through the channels in the spool to the right and into the cavity behind it, driving the rotary servo to maximum displacement (Figure 3.5).

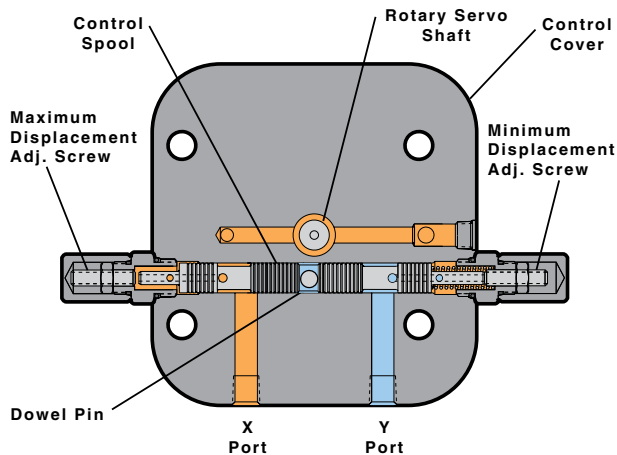

The cylinder control is provided with adjustable displacement stops. The maximum displacement stop is adjustable from 100-50% stroke, while the minimum displacement stop is adjustable from 30-75% stroke. The danger of overspeeding and the reduced efficiency make usage of a motor destroked to less than 30% undesirable. Orifices limit the response of the cylinder control to .6 second from full to 30% stroke. This control may be overridden by the rotary servo control at any time and in any direction up to the setting of the adjustable stops.

This control is intended to be a two position control with the two positions set by the maximum and minimum displacement stops. It is not capable of modulating the rotary servo setting to intermediate positions.

**PUMP TWO POSITION
CYLINDER CONTROL**
(2A* control)

This cylinder control (see Figure 3.7) is available for one side of center pumps. It consists of two equal length spools in the bore in the input control cover. This control is set to operate on one side of center only and is spring centered.

Applying 300 psi, 20.6 bar minimum pressure to port X puts pressure through the channel in the piston on that side. The force generated pushes the rotary servo pin against the spring loaded piston, causing the rotary servo to move to maximum stroke. When pressure is released and/or pressure is applied to port Y, the spring and/or pressure on the opposite spool causes the rotary servo to return to zero stroke.

Adjustable stops are used to set the zero stroke position and the maximum stroke position. This control is intended to be a two position control with the two positions set by the maximum and minimum displacement stops. If proportional pressure modulation of servo position is required, use the 800 control.

Figure 3.7
Pump two position cylinder control

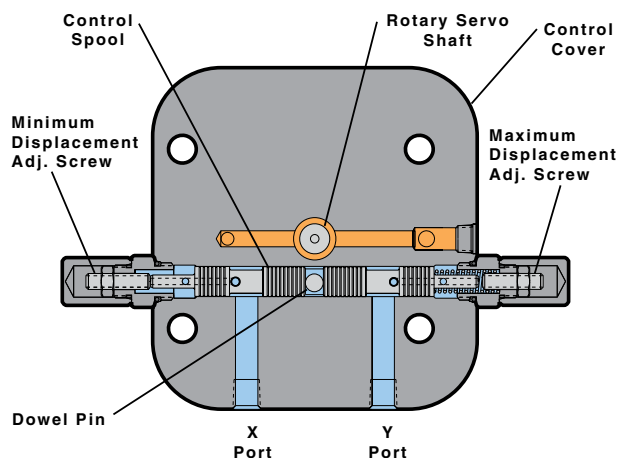
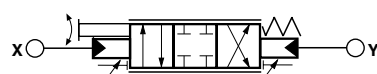

**PUMP THREE POSITION
CYLINDER CONTROL**
(2H* control)

The three position cylinder control (see Figure 3.8) contains two bores. One bore contains two spring centering spools and springs. A centering pin engages these spools and attaches to the rotary servo arm through a slot in the cover. The center position adjustment intersects this bore, providing positive centering adjustment.

The other bore contains two stroking spools connected to ports X and Y. A stroking pin engages these spools and attaches to the rotary servo arm through another slot in the cover.

Applying pressure to port X puts pressure through the channel in the right stroking spool and into the cavity behind it. The force generated pushes the stroking pin, causing the servo arm to rotate CCW, till the left stroking spool contacts the left maximum displacement adjustment screw. Simultaneously, the centering pin pushes the right centering spool away from the center position adjustment and against the right centering spring. When pressure is removed, the spring reverses this action till the centering spool again contacts the center position adjustment.

In the same manner, applying pressure to port Y causes the servo arm to rotate CW till the right stroking spool contacts the right maximum displacement adjustment screw.

This control is intended to be a three-position control with the two energized positions set by the two maximum displacement stops, and the center position set by the center position adjustment. Center position is adjustable $\pm 5\%$. Maximum displacements are fully adjustable.

Figure 3.8
 Pump three position cylinder control

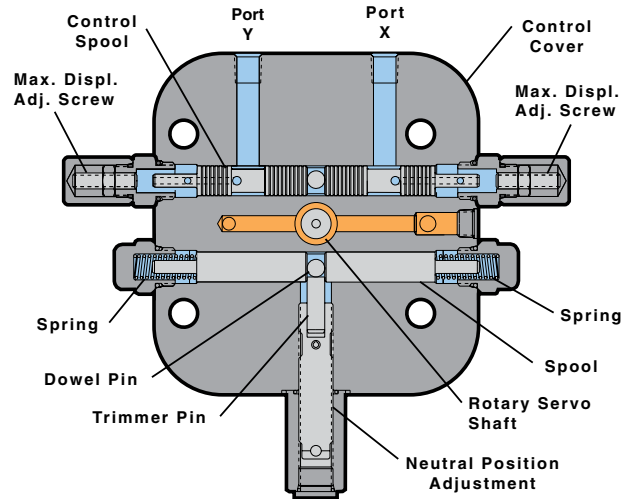
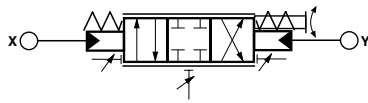

MOTOR ELECTROHYDRAULIC CYLINDER CONTROL
 (2M* motor control)

The motor 2M control is a 2A cylinder control with a single solenoid D03/NG6 electric valve mounted on the control, thus eliminating the need to mount separately a directional control valve and the fluid lines associated with it. The basic control is spring offset to max. displacement and will stroke towards 30 - 75% stroke when the solenoid is energized.

Figure 3.9
 Motor electrohydraulic cylinder control (full stroke)

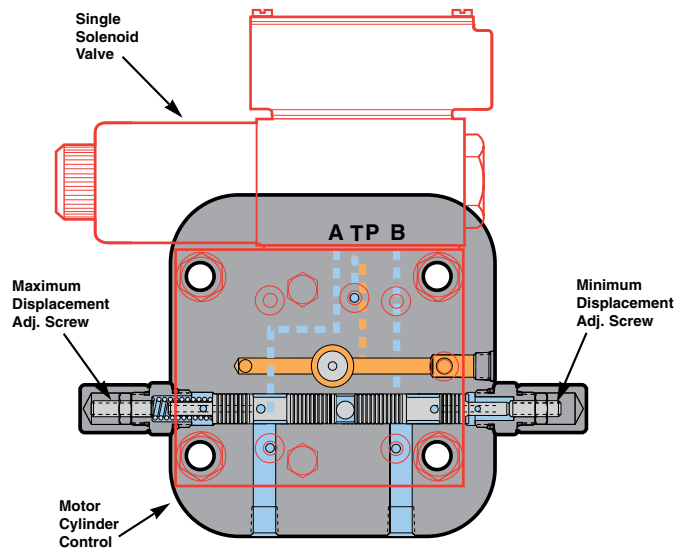
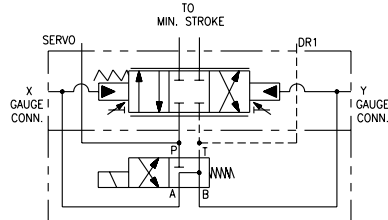

PUMP TWO POSITION ELECTROHYDRAULIC CYLINDER CONTROL
 (2M* pump control)

The pump 2M control is a 2A cylinder control with a single solenoid D03/NG6 electric valve mounted on the control, thus eliminating the need to mount separately a directional control valve and the fluid lines associated with it. The basic control is spring centered, and will stroke one side of center, to provide flow from the "B" port when the solenoid is energized.

Figure 3.10
 Pump two position electrohydraulic
 cylinder control (zero stroke)

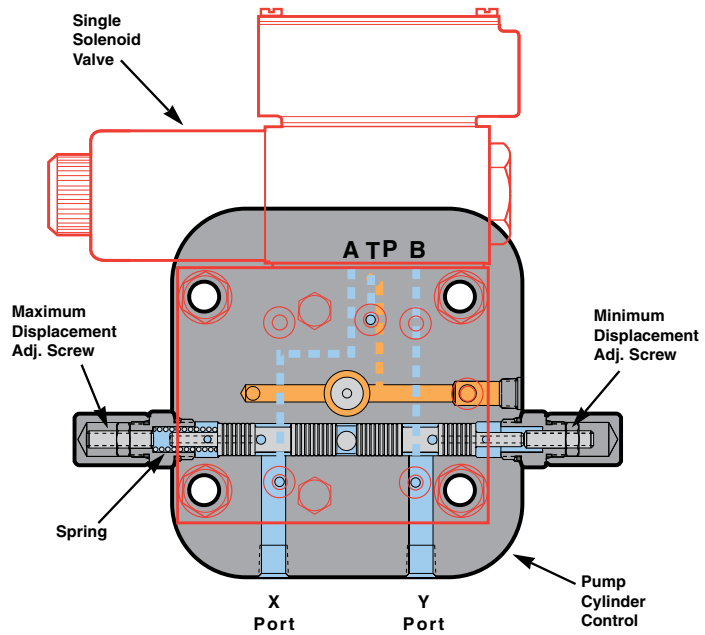
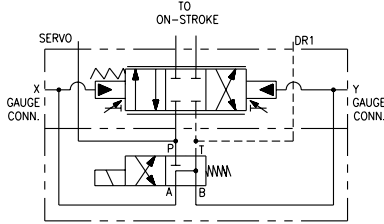

**THREE POSITION
 ELECTROHYDRAULIC
 CYLINDER CONTROL**
 (2N* control)

The pump 2N control is a 2H cylinder control with a double solenoid D03/NG6 electric valve mounted on the control, thus eliminating the need to mount separately a directional control valve and the fluid lines associated with it. The neutral position is adjustable to zero stroke $\pm 5\%$. Energizing either solenoid will place the pump on stroke against the corresponding maximum displacement stop. Maximum displacements are fully adjustable.

Figure 3.11
 Three position electrohydraulic
 cylinder control (zero stroke)

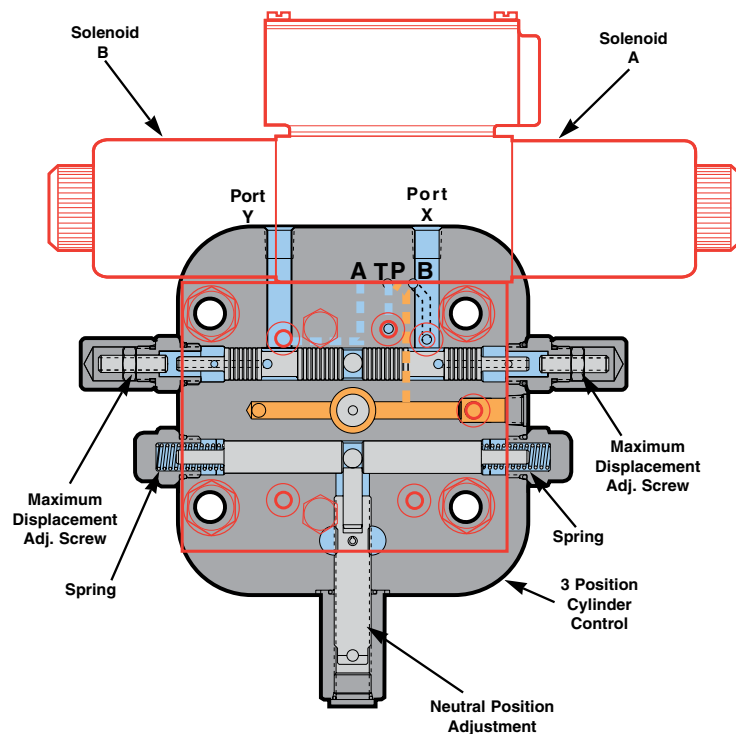
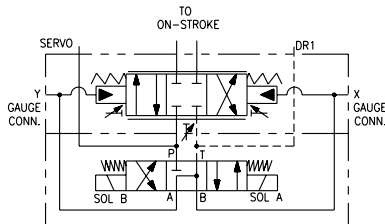

AUTOMATIC BRAKE AND NEUTRAL BYPASS CONTROL

Figure 3.12
 Automatic brake and neutral bypass control 400 and 500 series
 (input and output at zero stroke)

The automatic brake and bypass control is used in circuits which cannot tolerate creeping of the actuator or motor when the pump is in the neutral position. It is intended primarily for use in hydrostatic transmissions, but is usable in other type circuits. The control will relieve servo pressure from the brake port in order to allow a springset brake to set, and opens a bypass across both work ports to prevent any buildup of pressure differential across them. For the above conditions to be met, both the rotary servo input and the rocker cam must be simultaneously in the neutral position. If the input rotary servo and the rocker cam are not coincident in the neutral position, pressure is maintained on the pressure released brake and the bypass between the system ports remains blocked.

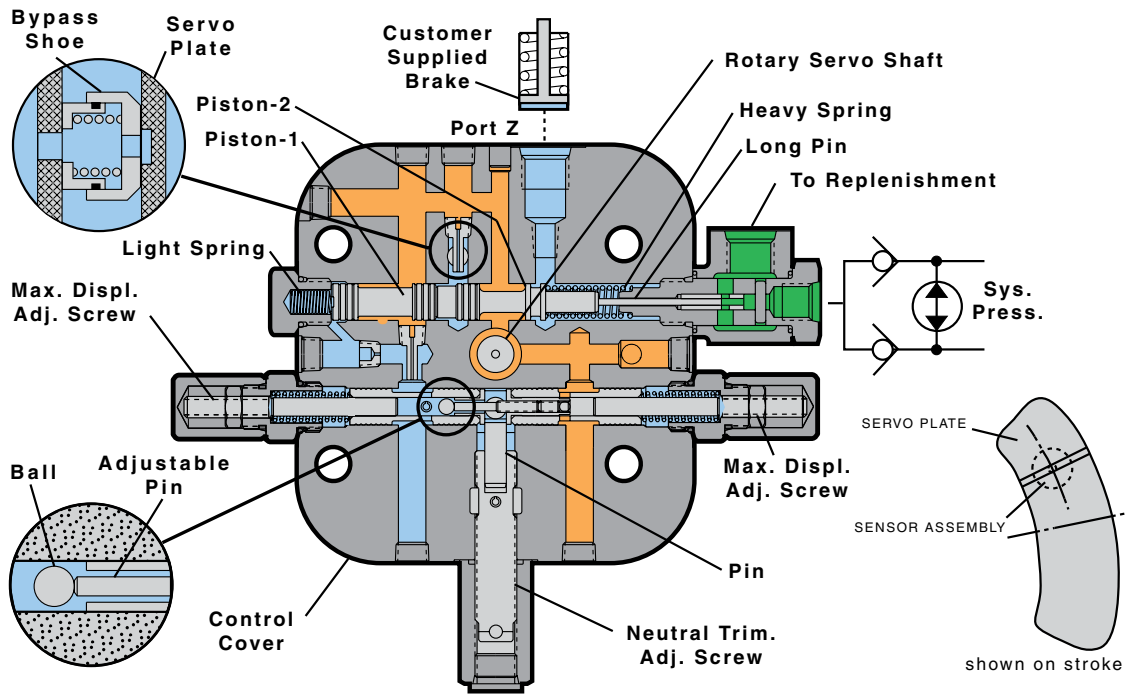
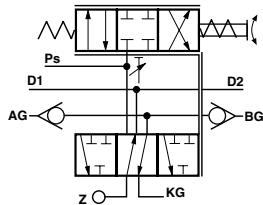

The bypass consists of two tees with integral check valves connected to the high pressure work ports (see Figure 3.12).

When the bypass is opened, any pressure buildup in the high pressure work ports will open one of the small check valves and allow flow into the bypass port. This port is open to the replenishing gallery and the oil flows through the gallery and into the opposite work port at replenishing pressure.

(400 and 500 series)

When both the input rotary servo control and the rocker cam are coincident in the neutral position, the ball in the control cover (see Figure 3.12) is held off its seat by the adjustable pin and a hole in the brake and bypass shoe is open to case pressure. This vents the pressure from two cavities which are connected through small orifices to servo pressure. These cavities are connected to areas on top of both pistons and the pistons move to the left in the bore. This opens the brake port to case pressure and permits the long pin to shift, opening the bypass valve.

When both the rotary servo input control and the rocker cam are on stroke (see Figure 3.13), the ball is no longer held off the seat by the adjustable pin (the pin is either moved away from the ball and seat, or the ball and seat are moved away from the pin) and the hole through the brake and bypass shoe is plugged off by the servo plate. This stops the flow through the two orifices and allows pressure to build to servo pressure in the areas to the left of both pistons. This forces the pistons to the right in their bore, opening the brake port to servo pressure and closing off the bypass valve with the long pin.

Figure 3.13
Automatic brake and neutral bypass
400 and 500 series
(input and output on stroke)

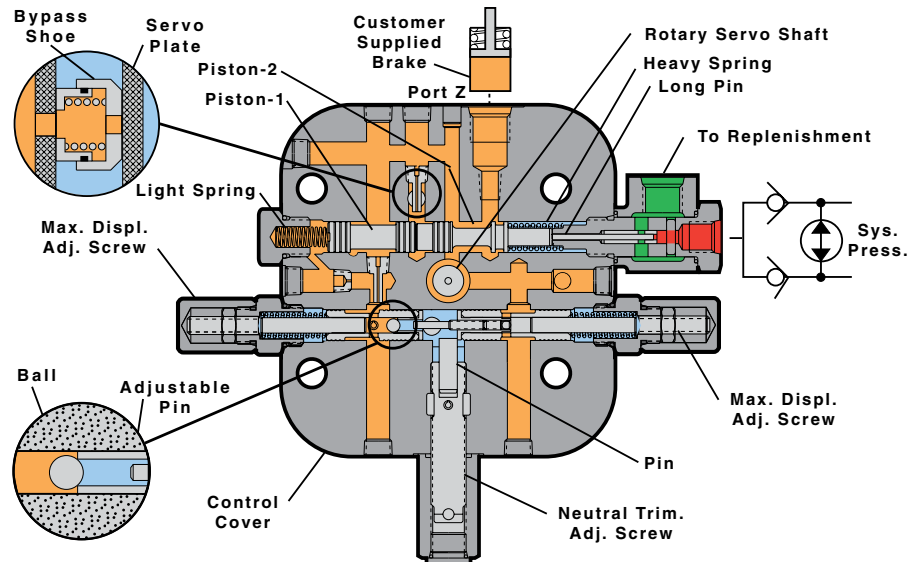

When the input rotary servo is in the neutral position, but the rocker cam is still on stroke (for example during dynamic braking), the ball is held off the seat, venting the area to the left of the piston-1; however, the hole in the brake and bypass shoe is still plugged by the servo plate, keeping servo pressure on piston-2. Piston-2 remains in position, keeping the long pin blocking the bypass port and the brake port open to servo pressure. This is shown in Figure 3.14.

When the input rotary servo is on stroke and the rocker cam is at zero stroke (for example, when the rotary servo is initially stroked off of neutral or the transmission is changing direction of rotation) the ball seats, blocking flow and allows servo pressure to build on piston-1. This pressure and the light spring force both pistons to the right, keeping the brake port open to servo pressure and the bypass port closed.

The brake and neutral bypass control has spring centering with a neutral adjustment. The neutral adjustment can be adjusted for $\pm 5\%$ pump stroke. Adjustable maximum volume displacement stops are available as an option and can be set anywhere from zero to 100% stroke. By disassembling the control and adjusting the position of the adjustable pin, the neutral deadband can be varied. If the pin is shortened (less motion to seat the ball) the deadband will be reduced.

Figure 3.14
Automatic brake and neutral bypass
(400 and 500 series)
(input zero, output on stroke)

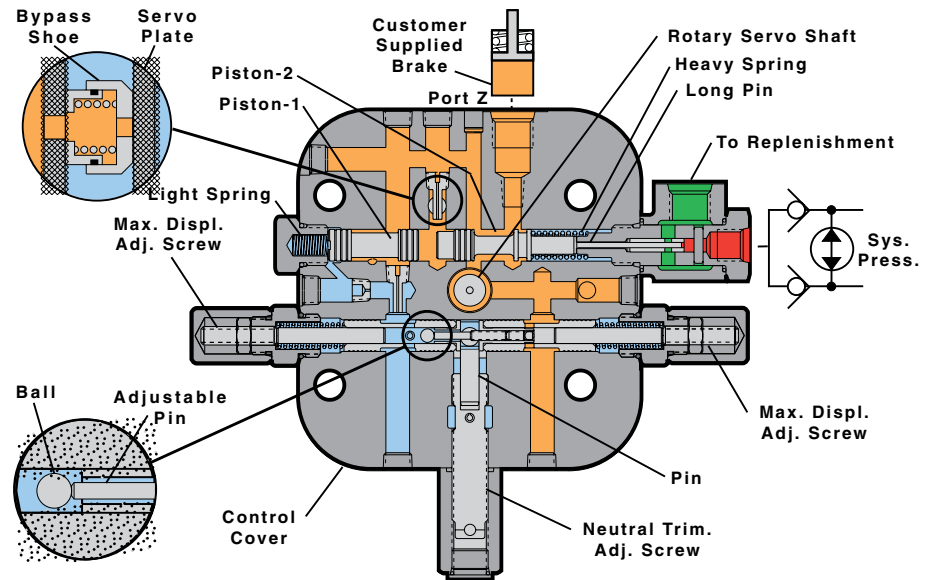

(800 and 900 series)

When both the input rotary servo control and the rocker cam are coincident in the neutral position, (see Figure 3.15) the centering trimmer sleeve and mating spool are positioned to bypass pilot flow to case, and a hole in the brake and bypass shoe is open to case. This vents the pressure from the two cavities which are connected through small orifices to servo pressure. These cavities are connected to the left of both pistons and the spring causes the pistons to move to the left in the bore. This opens the brake port to case pressure and permits the bypass valve spool to shift, connecting the pressure port to the replenishing port.

When both the input rotary servo control and the rocker cam are on stroke, (See figure 3.16) the centering trimmer sleeve and mating spool are positioned to block pilot flow to case, and the hole in the brake and bypass shoe is plugged off by the servo plate. This allows pressure to build to servo pressure in the areas to the left of both pistons. This forces the pistons to the right in their bore, opening the brake port to servo pressure and closing off the connection between system pressure and replenishing ports.

When the input rotary servo control is on stroke but the rocker cam is at zero stroke, (for example, when the rotary servo is initially stroked off of neutral or the transmission is changing direction of rotation), the hole in the brake and bypass shoe is open to case, but the centering trimmer sleeve and mating spool are positioned to block pilot flow to case. This allows pressure to build to servo pressure in the area to the left of piston -1. This forces both piston -1 and piston -2 to the right in the bore, opening the brake port to servo pressure and closing off the connection between pressure and replenishing ports.

When the input rotary servo control is in the neutral position but the rocker cam is on stroke, (for example, during dynamic braking), the centering trimmer sleeve and mating spool are positioned to bypass pilot flow to case, however the hole in the brake and bypass shoe is plugged off by the servo plate. This allows pressure to build to servo pressure in the area to the left of piston -2. This forces piston -2 to the right in the bore, opening the brake port to servo pressure and closing off the connection between pressure and replenishing ports.

A feedback connection tee'd off the brake port, through an orifice to the end of piston -1 provides toggle action shifting.

The brake and neutral bypass control has spring centering with a neutral adjustment. The neutral adjustment can be adjusted for +/- 5% pump stroke. Adjustable maximum volume displacement stops can be set anywhere from zero to 100% stroke.

Figure 3.15
 Automatic brake and neutral bypass
 (8C* and 9C* series)
 (zero stroke)

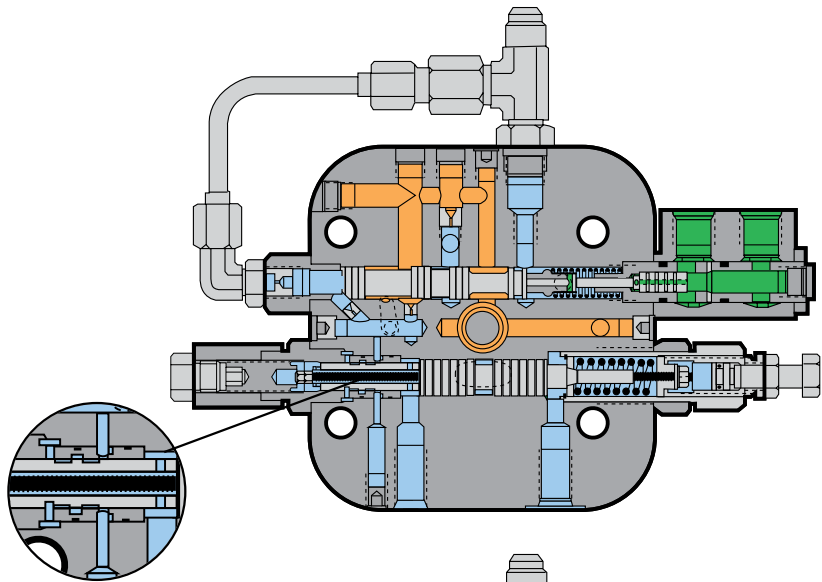
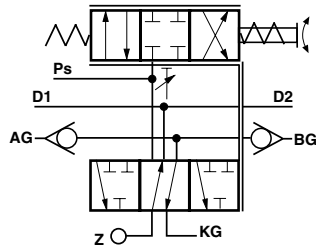
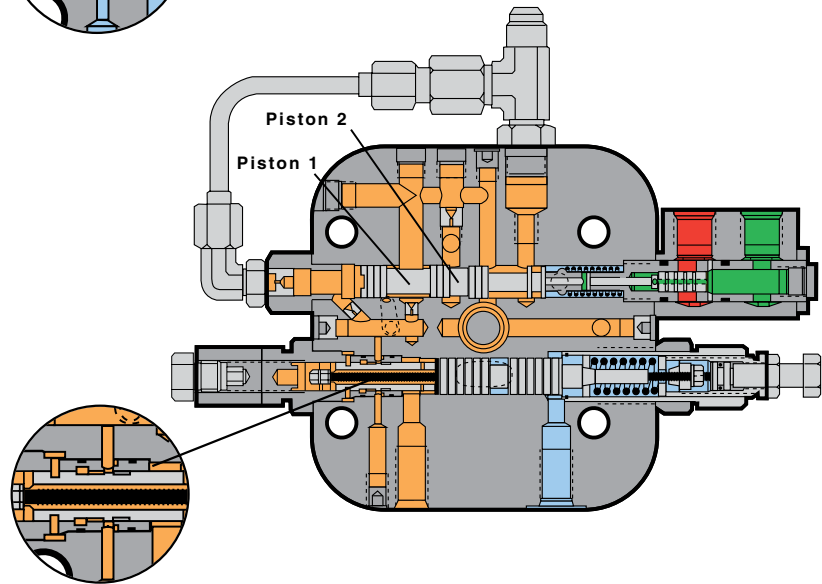

Figure 3.16
 Automatic brake and neutral bypass
 (8C* and 9C* series)
 (full stroke)



TORQUE LIMIT OVERRIDE CONTROL

The torque limit override control is designed to limit the input shaft torque required to drive the pump. In operation, the torque limit override maintains a relationship between displacement and pressure which results in a fixed limit on the input torque to the pump. The control operates by porting system flow into the control chamber, overriding the servo command, as the pressure or the displacement of the pump increases.

If the pump is operating at a constant speed, this control is also a horsepower limiting control. The horsepower setting of the pump changes in direct proportion to the input speed. Since GOLD CUP® pumps are hydrostatic transmission pumps, the torque limit override control is required to work on both sides of center. It has been designed to allow the torque limits to be set differently for both sides of center, if required. The torque limit override does not control when the hydrostatic transmission is in dynamic braking, providing stability.

The circuit for the torque limit override control is shown in Figure 3.17. Oil at servo pressure is fed to a pair of pressure compensated flow control valves, each of which meters a constant small oil flow to a variable orifice (shoe controlled orifice). As the displacement of the pump increases on one side of center, the variable orifice for that side of center increases its opening. The pressure at the variable orifice is reduced. This pressure is directed to the intensifier valve made up of the piston, pin, and body with a cross-drilled port. The intensifier ratio is 12.25 to 1.

The pump system pressure port (A or B as applicable) is connected to the end of the pin. When system pressure exceeds 12.25 times the pressure on the end of the piston, the pin shifts, porting pressure to the cross drilled hole. The cross drilled hole is connected to the override tube on the pressure side, causing the stroke to reduce. As the stroke reduces, the shoe controlled orifice reduces in size, increasing the signal pressure until a balance is obtained.

For operation on the other side of center, the opposite flow control, intensifier piston and shoe orifice are in control. The first shoe orifice is blocked and servo pressure is applied to the shoe balance area through that path. By keeping this orifice blocked, the pump is prevented from limiting while dynamic braking.

Figure 3.17
Torque limit override circuit

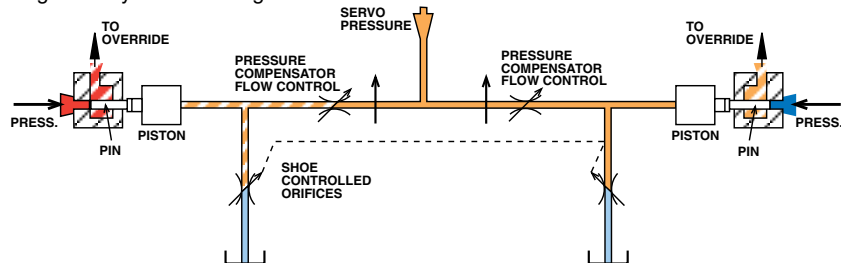

A special designed servo shoe (torque limit override shoe see Figure 3.18) forms the variable orifice in conjunction with the feedback cover plate. The shoe is carried in the feedback arm and travels against the control cover. Since the feedback arm is trapped by the bolt heads in the balance plate (see internal configuration chapter) the torque limit override shoe follows with pump displacement.

In the control cover, a pair of small holes are located over the torque limit override shoe (see Figure 3.18). A pair of comet-tail shaped grooves (shown darkened) in the shoe are positioned so they will travel under one or the other of the holes in the cover plate when the pump is on stroke. The combination of these holes and grooves forms the variable shoe controlled orifices.

Figure 3.18
Torque limit override shoe

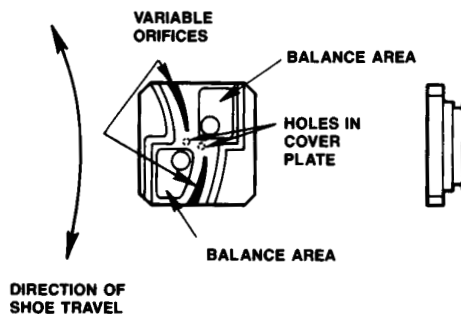

As the pump moves off of neutral in one direction, one groove travels under its corresponding hole and “opens” the orifice. As the pump increases stroke further, the variable orifice enlarges. Only one orifice is “open” at a time. The orifice which is open controls an intensifier valve which is connected to the gage port for the outlet port. The closed orifice is connected to the low system pressure side and is inactive. When the pump rocker crosses center, the pump reverses flow and the orifices exchange functions.

By keeping the one orifice closed, the pump is prevented from being torque limited while dynamic braking.

Figure 3.19 is a simplified drawing of the feedback control cover containing the torque limit override control. Oil at servo pressure flows from the servo stem through the orifices formed by the limiter adjusting screws. The pressure drop across these screws is held constant by the pressure compensator spools downstream of the orifices. The controlled flows pass by the pistons in the intensifier valves and out the holes in the side covers which connect to the variable orifices. For the side of the control connected to the side of the pump which is pressurized during dynamic braking, the hole in the side cover is connected with servo pressure. This keeps the corresponding intensifier piston and control pin in the closed mode.

The torque limit override control is contained in the feedback control cover. This allows it to be used with any of the other control options without further changes to the pump.

Figure 3.19
Torque (horsepower) limit override

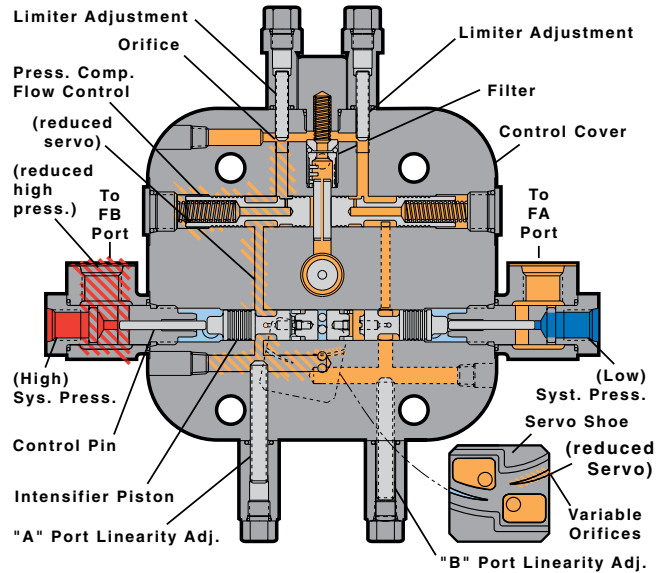
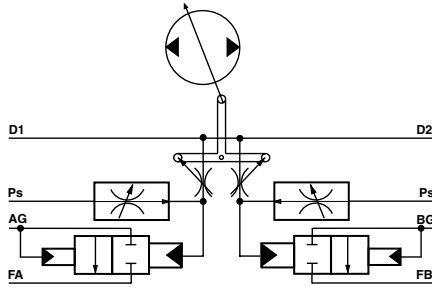

The electrohydraulic stroker provides a modulating rotary servo position proportional to the input current. It does not require electrical displacement feedback.

ELECTROHYDRAULIC STROKER

The electrohydraulic controller, consisting of a voice coil, jet pipe and piston, positions the rotary servo shaft, which controls the rocker cam position. With a zero current input, the voice coil exerts no force, and the two springs center the jet pipe between the two receivers. If the null adjusting screw is set so that the jet pipe is exactly centered between the receivers, the jet stream splits evenly to produce the same pressure in each receiver (see insert Figure 3.20). These pressures are connected to corresponding ends of the piston and, being equal, create no motion.

Figure 3.20
Electrohydraulic stroker
(500 series)
(Zero stroke)

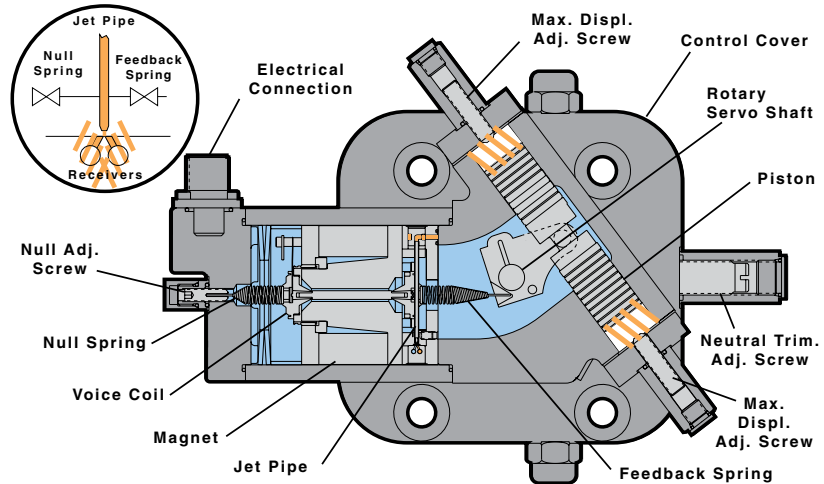
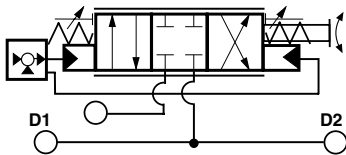

If current is applied to the voice coil (see Figure 3.20), it exerts a force on the armature in proportion to the magnitude and polarity of the current. This causes the jet pipe to deflect so that it is aimed more directly at one receiver pipe. The pressure in that pipe rises and the pressure in the other pipe falls, causing the pressures on the ends of the piston to change accordingly. The piston then moves, rotating the servo shaft and either compressing or relaxing the feedback spring, depending on the direction of motion. When the piston moves far enough so that the change in feedback spring force equals the voice coil force the jet pipe re-centers and the piston stops at that position.

If current is reduced again to zero, the loss of voice coil force allows the feedback spring to shift the jet pipe in a direction to return the piston to the zero stroke position.

Figure 3.21
Electrohydraulic stroker
(Full stroke)

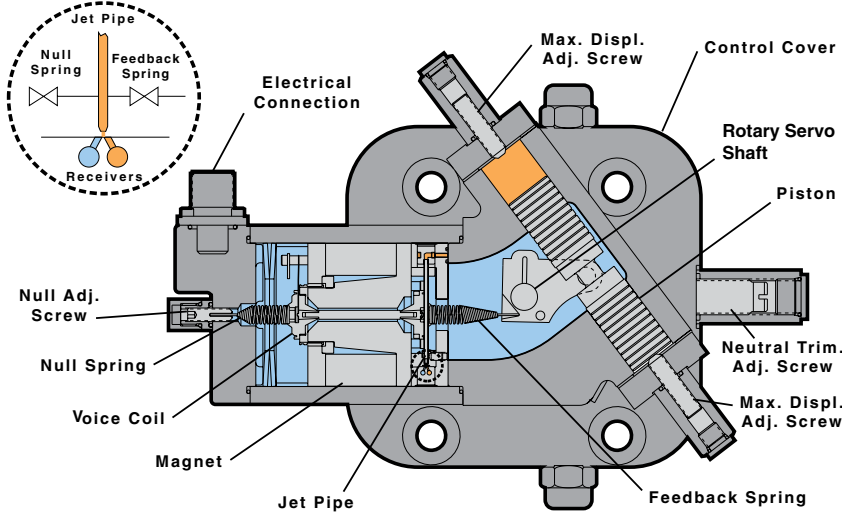

With the separate servo pressure feed to the control shut off, the rotary servo may be moved manually.

The control is available only with the spring centered rotary servo, brake and neutral bypass or torque limit override. Adjustable maximum volume stops are provided in standard configuration. They are capable of being adjusted between zero and full displacement. The relationship between the number of turns of an adjusting screw and the cam angle is: 1 turn = 2.23° cam angle

The control is available with 0 deadband or with 10% deadband on zero stroke position.

Figure 3.22
Stroke vs. current

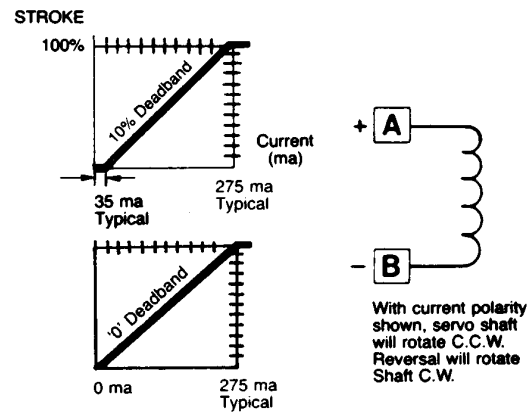

HYDRAULIC STROKER (800 SERIES)

The hydraulic stroker modulates the rotary servo position in proportion to an externally supplied hydraulic pressure.

The hydraulic controller, consisting of a stroking piston and spring box, positions the rotary servo shaft. With no external control pressure input, the piston is positioned by the spring box; at zero displacement for pump controls, or at full displacement for motor controls.

When an external pressure is introduced into one of the control ports, a force develops, proportional to the pressure times the piston area. When this force exceeds the spring preload, the piston commences to move in its bore, a distance proportional to the signal pressure. A pin engaging the piston converts the piston motion into a proportional rotation of the rotary servo shaft.

When the control pressure is reduced or removed from the control port, the rotary servo position reduces or returns to the initial position. Introducing signal pressure into the opposite port results in motion in the opposite direction.

With no pressure applied to either control port, the rotary servo may be moved manually by applying external torque capable of overcoming the spring force, typically 30 to 60 lbs-in., 3,4 to 6,8 Nm.

Adjustable displacement stops are standard. On pump controls, stops are adjustable from maximum to zero displacement. On motor controls, internal locknuts prevent reducing minimum displacement below 30% displacement. Minimum and maximum displacements are fully adjustable within this range.

The hydraulic stroker is also available with automatic brake and neutral bypass control

A variety of control pressure ranges are available:

<u>PUMP CONTROL PRESSURE</u>		
<u>CONTROL FEATURE</u>	<u>PRESSURE START</u>	<u>PRESSURE FULL</u>
00	75 ±15 psi, 5,2 ±1 bar	335 ±25 psi, 23,1 ±1,7 bar
01	75 ±15 psi, 5,2 ±1 bar	435 ±25 psi, 30 ±1,7 bar
02	100 ±15 psi, 6,9 ±1 bar	375 ±25 psi, 25,9 ±1,7 bar
03	150 ±15 psi, 10,3 ±1 bar	400 ±25 psi, 27,6 ±1,7 bar
04	75 ±15 psi, 5,2 ±1 bar	250 ±25 psi, 17,2 ±1,7 bar

<u>MOTOR CONTROL PRESSURE</u>		
<u>CONTROL FEATURE</u>	<u>PRESSURE START</u>	<u>PRESSURE FULL</u>
0	75 ±15 psi, 5,2 ±1 bar	250 ±25 psi, 17,2 ±1,7 bar
1	250 ±15 psi, 17,2 ±1 bar	450 ±25 psi, 31 ±1,7 bar

Figure 3.23
 Hydraulic stroker (centered)
 (8** control)

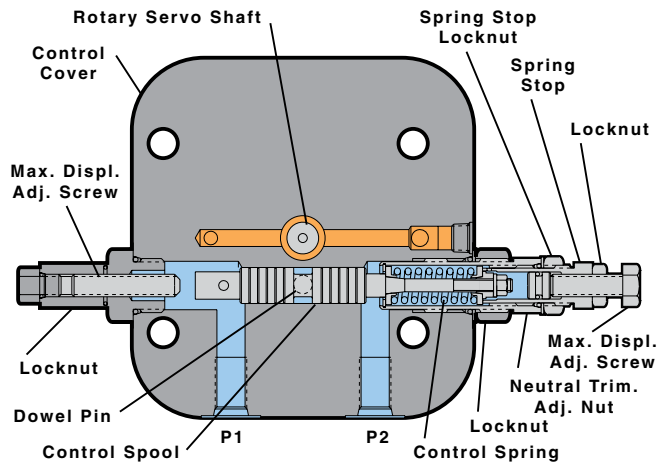
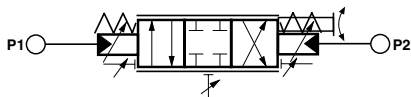
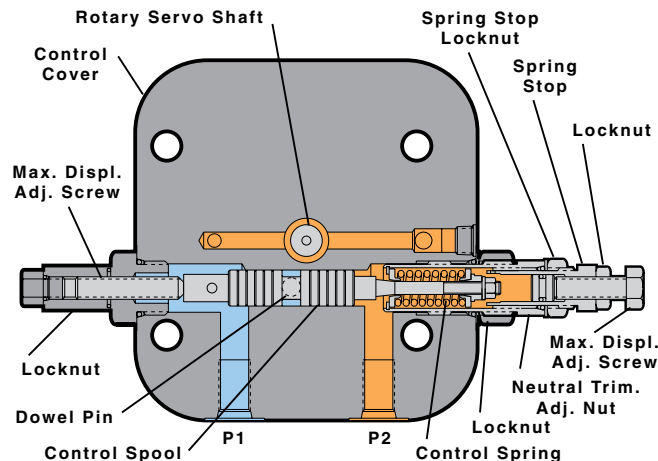

Figure 3.24
 Hydraulic stroker (on stroke)



ELECTROHYDRAULIC SERVO
 (7** control)

The electrohydraulic servovalve Figure 3.25 is mounted on the top of the valve block, where the work ports are ported to the override tubes. The valve block is also designed to supply a constant servo pressure of 400 psi, 27,6 bar to the servovalve. A spool shifts to restrict the servovalve tank port when the pressure compensator is active to prevent loss of control flow through the servovalve tank port.

A feedback control replaces the standard output indicator to provide an electrical signal of pump stroke. Feedback may be obtained from a potentiometer, or from a DC rotary variable differential transformer powered by a 15 volt DC signal. This control system is capable of high response and precision control in closed loop servo controlled systems, while maintaining the capability for pressure compensator override.

Figure 3.25
 Electrohydraulic servovalve(HI-IQ)

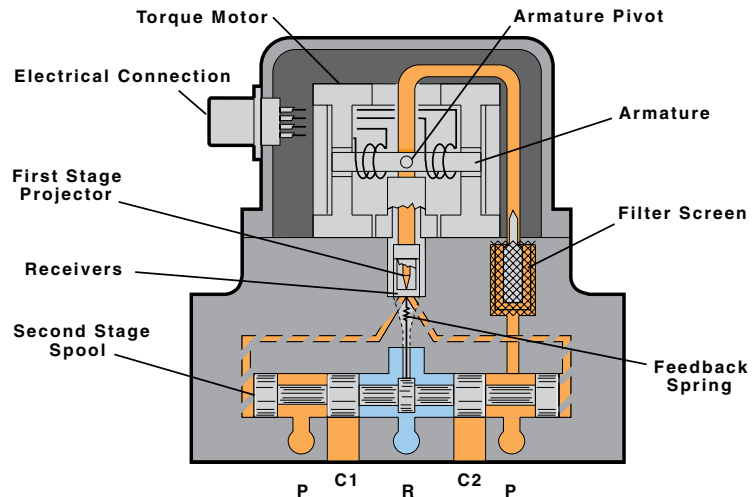
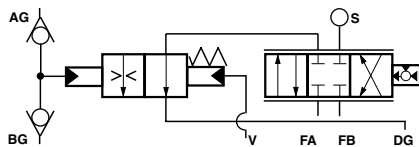

ELECTROHYDRAULIC STROKER (900 SERIES)
 (9** control)

The 900 series electrohydraulic stroker modulates the rotary servo position in proportion to an electrical input current.

The controller consists of an electrical proportional valve, which establishes a control pressure in proportion to the electrical input current. This control pressure is then applied to a stroking piston and spring box, to position the rotary servo shaft. With no external input, the piston is positioned by the spring box; at zero displacement for pump controls, or at full displacement for motor controls.

When an external pressure is introduced into one of the control ports, a force develops, proportional to the pressure times the piston area. When this force exceeds the spring preload, the piston commences to move in its bore, a distance proportional to the signal pressure. A pin engaging the piston converts the piston motion into a proportional rotation of the rotary servo shaft.

When the control pressure is reduced or removed from the control port, the rotary servo position reduces or returns to the initial position. Introducing signal pressure into the opposite port results in motion in the opposite direction.

With no pressure applied to either control port, the rotary servo may be moved manually by applying external torque capable of overcoming the spring force, typically 30 to 60 lb-in., 3,4 to 6,8 Nm.

Adjustable displacement stops are standard. On pump controls, stops are adjustable from maximum to zero displacement. On motor controls, internal locknuts prevent reducing minimum displacement below 30% displacement. Minimum and maximum displacements are fully adjustable within this range.

For cross-center operation, a proportional valve is required for each side of center. For one side of center operation and for motor controls, a single proportional valve is sufficient.

The Jupiter driver card has been designed to control the electrohydraulic stroker with 24 volt coil. Deadband is adjustable to 10% of full scale.

The 900 series electrohydraulic stroker is also available with automatic brake and neutral bypass control. (Figure 3.15 and 3.16)

Figure 3.26
900 series electrohydraulic stroker

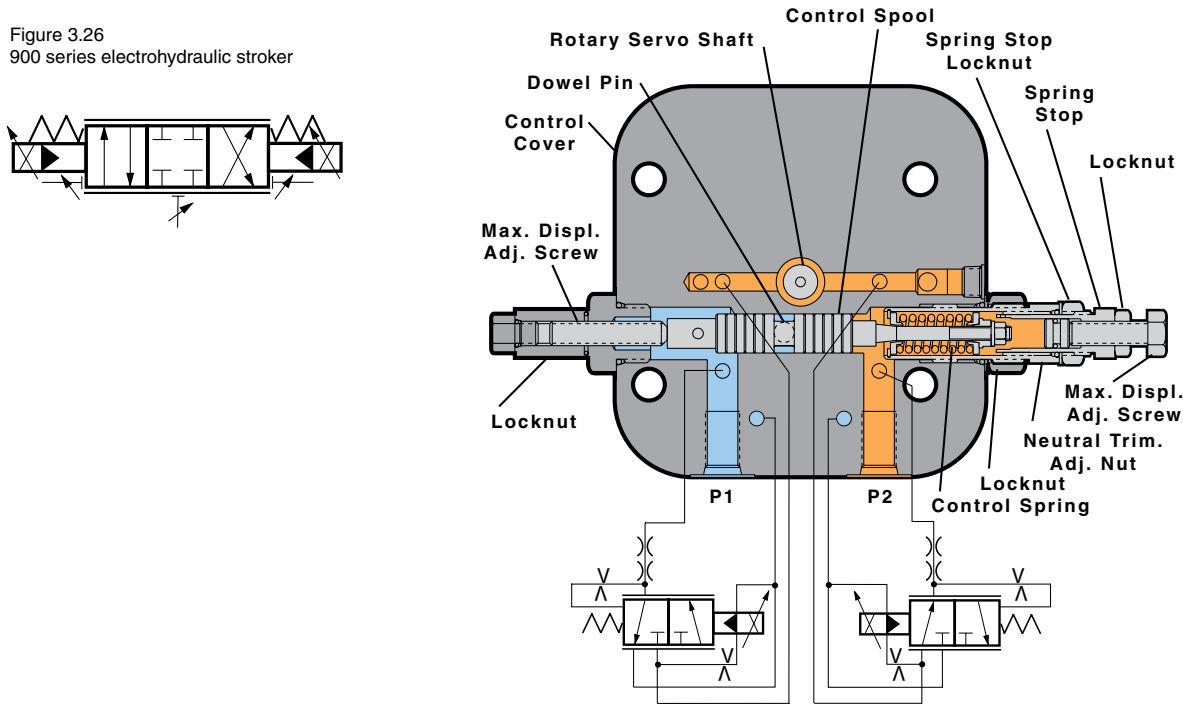
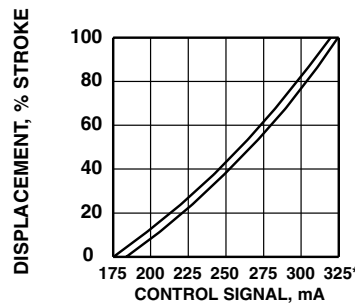
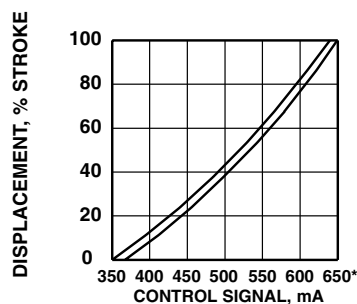

Figure 3.27
900 series electrohydraulic stroker
displacement vs. current, 24 Volt coil



* NOTE: The input current shown in the chart is typical, however, the maximum threshold to achieve 100% displacement could be up to 380mA.

Figure 3.28
900 series electrohydraulic stroker
displacement vs. current, 12 Volt coil



* NOTE: The input current shown in the chart is typical, however, the maximum threshold to achieve 100% displacement could be up to 780mA.

GOLD CUP® APPLICATIONS SUGGESTIONS

INTRODUCTION

REMOTE CONTROL OF PRESSURE COMPENSATOR OVERRIDE

In conjunction with the standard control features available on the GOLD CUP® pumps, many sophisticated control concepts may be realized without extensive external circuitry. These concepts operate on the pressure compensator override and rotary servo to expand the control capabilities of the hydrostatic transmission.

This section discusses control concepts which use devices not totally integrated in the pump or motor packages. It also deals with many aspects of pump and motor control which need to be considered by most original equipment manufacturers.

The pressure compensator override control on GOLD CUP® series pumps may be remotely controlled and/or vented in three modes: A side only, B side only, or both sides. Individual vent ports, each isolated from the other may be remotely controlled or vented, which results in one side of the pump being limited to a lower pressure. A common vent port controls the PCOR setting on both sides of the pump.

Venting of the compensator directly to tank lowers the maximum system pressure to approximately 200 psi, 13,8 bar above servo pressure. When vented, the entire output flow of the pump is available to be used to destroke it. Excess flow is diverted cross-port through the dual level relief and replenishment checks to the opposite port (see circuitry, section 2).

Note: Rapid venting while under pressure can cause damage to the pump. As a rule of thumb control the rate of venting to allow 1/2 to 1 second to go from 5000 psi, 345 bar to minimum pressure. Figure 4.1 demonstrates one method to accomplish this. The small accumulator and orifice provide about 1/2 to 1 second venting time. The check valve prevents the accumulator from affecting the compensator setting except for the first recharge. The orifice size will affect the minimum venting pressure. Orifice size and accumulator size should be based on compression volume, minimum vented pressure, and acceptable venting time.

Figure 4.1
 Circuit to control speed of venting compensator

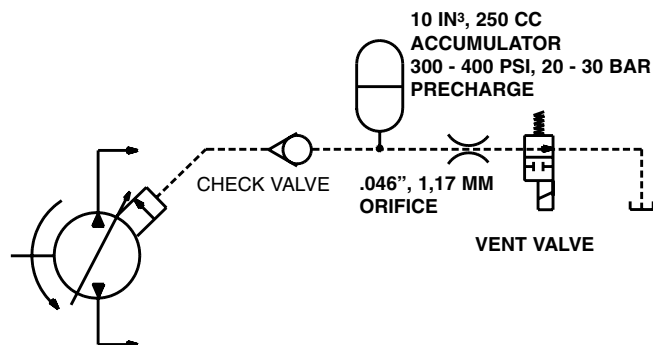

Remote control of the compensator is accomplished by connecting a pressure regulating valve or pressure source to any of the three vent ports. When the pressure at the vent port is higher than the PCOR pilot section, the pilot section is in command. When the pressure at the vent port is lower, the external pressure sets the compensator pressure level.

If a vent or remote control is to be connected to more than one pump at a time, isolation checks must be installed to prevent one pump from lowering the pressure setting of the other (See Figure 4.2).

Figure 4.2
 Remote control of multiple PCOR

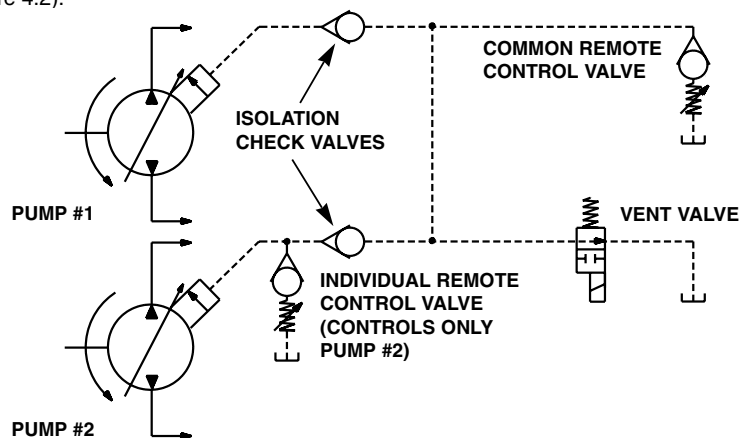
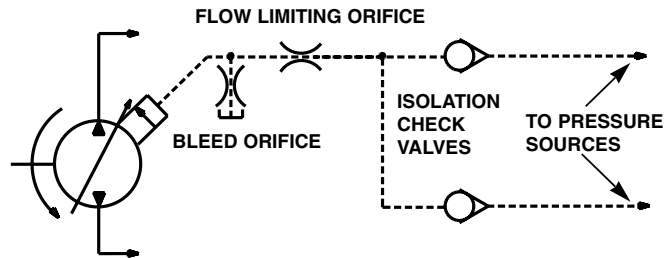

Figure 4.3
 Remote control of PCOR by pressure sources



LOAD SENSING

When pressure sources are used to control the PCOR, the isolation checks will have to be reversed. (See Figure 4.3). Under these conditions it may be necessary to install bleed orifices to insure the pressure in the line between the isolation check and PCOR vent port will drop off when the pressure source does. Flows from pressure sources must be limited to prevent overpowering the PCOR pilot section if it must take over control.

In hydraulic circuits where multiple functions are driven from a single pump, it has been common practice to use a fixed displacement pump and open center valves. In these circuits, the control valves throttle flow and pressure into the load circuit, where the actuator operates at the speed commanded by the opening of the valve and the pressure required by the load. Since the pump is a fixed displacement pump, excess flow must be bypassed through a system relief valve to the reservoir. This relief valve must be set to the highest required pressure in order for the machine to operate satisfactorily. The pump must be sized to produce adequate flow so the machine will operate at its designed speed when many functions are simultaneously engaged.

The fixed displacement pump operating at a fixed pressure uses maximum horsepower all the time the functions are engaged and, therefore, the machine is very inefficient during periods of light load or when few functions are being used.

To reduce these horsepower losses and high heat loads the concept of load sensing has been devised. Load sensing means that the pump output pressure will be set to the highest pressure required in the circuit at that instant in order to reduce the horsepower used. When used in conjunction with the pressure compensator override of the GOLD CUP® transmission pumps, load sensing not only reduces the output pressure of the pump to the highest required pressure, but also allows the pump to deliver only the flow required at that moment by the circuit. This offers additional horsepower savings over the system that operates on pressure only.

The diagram in Figure 4.4 shows a variable volume GOLD CUP® pump with a modified (no orifice in sequence poppet) pressure compensator override providing to two separate load functions through proportional flow control 4-way valves. To load sense a GOLD CUP® pump, it is necessary to connect the vent port of the pressure compensator override to the shuttle valve logic, which insures that the highest pressure is available to the output of the logic. This logic circuit is shown in the enclosed diagram as four shuttle valves. Each valve has one end connected to the individual system lines, while the other ends are tied together to the vent port. Installing the shuttle valves with the free flow direction leading from the system to the vent port insures that the highest pressure system leg is connected to the vent port. All other valves will be shut off by this higher pressure.

Figure 4.4
 Load sensing

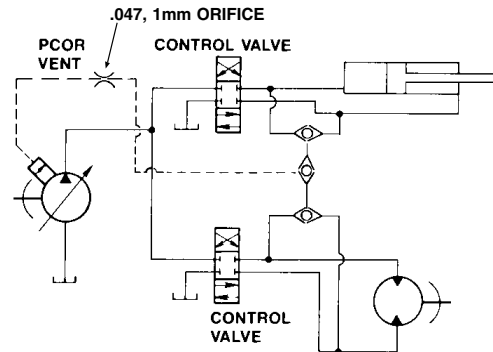

The circuit drawing (Figure 4.4) shows the directional control valves as closed center parallel valves. While these are the most desirable for this circuit, it is also possible to use parallel system, open center valves which are normally used with fixed displacement pumps. In this case, it is required to put some restriction or back pressure in the high pressure carry-over port in order to build the pressure drop in the neutral position above the minimum compensator setting of the pressure compensator override. With this back pressure added to the valves and when the valves are all in neutral position, the pump will be commanded to low pressure due to the absence of pressure in the load circuits, and will be held to minimum displacement. Without the back pressure, it is possible for the pump to be on stroke, although at low pressure.

In the closed center system shown, in the neutral position the pump will be at low pressure, again due to the lack of pressure in the load ports and will be at minimal flow due to the blocked center position of the valves.

The enclosed circuit shows shuttle valves providing the load sensing logic to the vent port of the pressure compensator override. Valve suppliers may provide this logic in the secondaries of the control valve stacks. These valves may also contain the bleedout orifices as well.

CONSTANT SPEED DRIVES

Some applications require constant controlled speeds from an actuator despite varying engine speeds. These applications include transit mixers, generators and refrigeration systems. The GOLD CUP® pumps can be readily adapted to this type of system by using the modified valve block with no orifice in the sequence poppet, with the addition of an orifice and a vent line as shown in the circuit in Figure 4.5.

Figure 4.5
Constant speed drive

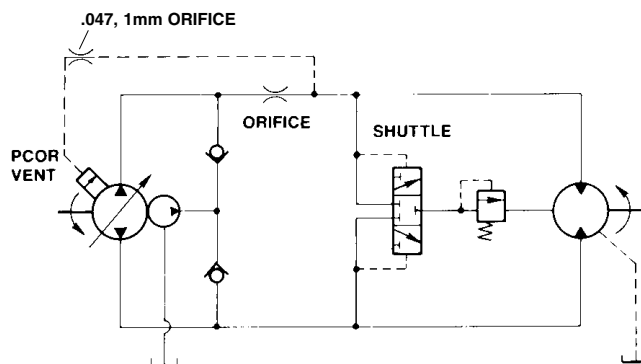

In this circuit, the top of the compensator sequence valve (see Circuitry Section 2) is connected to the load side of the orifice by the vent line. When the pressure drop through the orifice exceeds the pressure value of the spring on the sequence poppet the poppet rises and allows flow into the stroking chamber. This action is independent of system pressure as long as the pressure compensator override setting is not exceeded.

The above described system operates only in one direction of flow and only in the driving mode. It does not regulate speed in reverse or during overhauling loads. If speed control is desired in both directions, another orifice and vent line must be installed in the other system leg. If the system will reverse but regulation is not desired, a reverse flow check should be installed around the orifice. Even with additional vent lines and orifices in the opposite leg, regulation will occur only in the driving mode. If regulation is required while retarding, contact the Application Engineering Department.

DEAD MAN CONTROL

On certain types of machines, it is desirable to have a control which will prevent motion of the machine without an operator at the controls. Venting the compensator when the operator is not at his station will remove power from the transmission. Pump venting when under pressure should be avoided. Consult Parker if necessary to vent under pressure (see Figure 4.1). If the machine is not moving, it should remain stationary. If it is moving, it will coast until it stops. It should be noted that the machine will not stop rapidly with a vented compensator. If it is required to stop rapidly, or hold on a grade, the same sensor that vents the compensator should also set a parking brake.

**OVERHAULING LOADS
DYNAMIC BRAKING**

GOLD CUP® series hydrostatic transmissions are capable of dynamically braking loads and regenerating the horsepower back into the prime mover. Because of the pressure compensator override, the horsepower losses during dynamic braking will be minimal. The prime mover must accept full braking loads.

Under dynamic braking modes of operation the pump and motor in a hydrostatic transmission exchange functions. The motor, operating as a pump in this mode, has low pressure oil on its inlet and high pressure oil on its outlet. It is therefore transferring horsepower from its shaft to the hydrostatic loop. The pump, driven as a motor, converts hydraulic horsepower to mechanical horsepower and feeds it into the prime mover. In this mode, the pump has high pressure on its inlet and low pressure on its outlet.

Load absorption characteristics of prime movers are widely variant. Induction motors can generally absorb more horsepower than they can produce, while diesel engines will only absorb 20-30% of rated output. In some cases, the regenerative capabilities of the prime mover can be increased with the addition of special devices (e.g., Jacobs brakes on diesels). Consult the manufacturer of the prime mover if overhauling loads are to be encountered.

Component and system inefficiencies help dissipate some power and reduce the total regenerated horsepower seen by the prime mover. These losses include those of the gear boxes (both pump drive and at the load) and any other losses in the load drive mechanism.

If excess regenerated horsepower will be presented to the prime mover and all efforts to increase its absorption characteristics have been exhausted, other methods of energy dissipation must be employed. For traction drives large manually operated service brakes may be used to dissipate this energy. Other systems may have to use the hydraulic system to absorb the energy in the form of heat.

Open circuit hydraulic systems will absorb this heat and carry it to the cooler, usually without problem. Closed circuit systems will tend to hold the heat due to the small fluid exchange rate. If high overhauling loads have to be absorbed by hydrostatic circuits, extra replenishment flow should be added at a rate dictated by the heat rise expected in the loop.

**REPLENISHMENT
REQUIREMENTS**

For most applications, the replenishment flows available from the charge pump(s) contained in the package pump are adequate. There are, however, many applications where additional replenishment flows are necessary. These applications include:

- (1) low input speeds
- (2) systems with large compressible volume
- (3) multiple actuators-unequal area actuators
- (4) high leakage actuators
- (5) systems with high pressure drops

As explained in Circuitry Section 2, the GOLD CUP® package pumps are capable of accepting case drain oil in reverse to prevent cavitation. Case pressure replenishing is accomplished by routing the actuator drain flow to the pump drain port and then routing both drain flows over a 40 psi, 2,8 bar back pressure check. (See Figure 4.6)

Figure 4.6
Case pressure replenishment
circuit

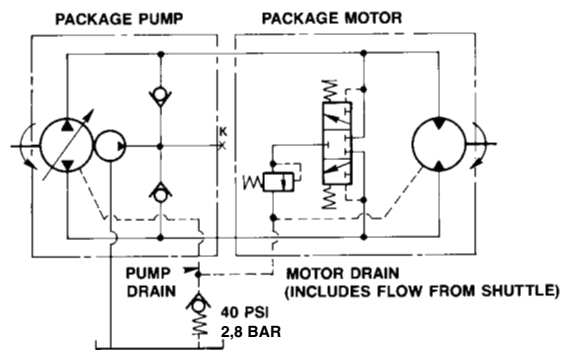

Case pressure replenishing will prevent cavitation of the hydrostatic pump during periods when the combined leakages of the pump and actuators exceed the replenishment flow from the charge pump(s). Under these conditions the flow introduced into the loop from the case drains is equal to the difference between leakage and charge pump flow. It should be used only for momentary requirements such as those that occur from low pump shaft speeds.

For applications which use multiple actuators or actuators with high internal leakage, it may be necessary to introduce additional replenishment flow from another source. These applications will suffer prolonged loss of replenishing pressure and temperatures and contamination levels will rise if case pressure replenishing is relied upon.

Circuits with high pressure drops will heat rapidly unless additional replenishing is added to flush hot oil from the loop. These circuits include closed circuit hoist circuits with counter balance valves or traction circuits with flow dividers.

Circuits which have long lines or other forms of large compressible volumes should have additional replenishment flows available; especially if rapid pressure changes or reversals are to be encountered. This flow may be obtained from accumulators plumbed into the auxiliary replenishment port. Under these conditions, case pressure replenishment offers little help.

Additional replenishing flows may be obtained from additional pumps or return oil from other circuits. (See Figure 4.7). Flow from an additional pump may be introduced to the auxiliary replenishment port continuously at replenishing pressure. Return flows from other circuits should be plumbed so they are introduced only as required. If these flows are cooled and filtered they may be introduced continuously.

Figure 4.7
Additional replenishment flow

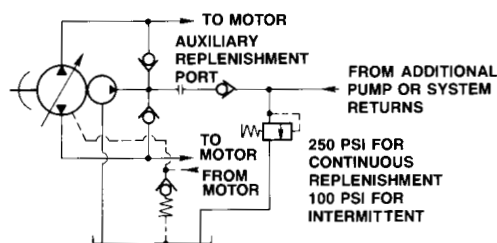

ENGINE STARTUP

Unlike electric motors, diesel engines are very reluctant to start under high loads, especially when cold. It is good practice to insure that the load is removed or disconnected prior to cranking. Manual or electrically controlled clutches are sometimes used, but are costly or inconvenient. The GOLD CUP® line of pumps offers a number of convenient and inexpensive methods for relieving loads during engine startup.

A small electrically operated two-way valve which vents the pressure compensator override can be used. Wired to the start position of the starter switch, the valve shifts to the open position during cranking and vents the compensator. In this condition, the pump is used to destroke its own rocker cam. When the engine fires and cranking stops, the valve closes, allowing the pump to readily follow rotary servo input commands.

A small capacity high pressure accumulator connected to the compensator vent port can provide an initial no-load period for cranking. With a low pressure precharge, the accumulator will be empty of oil when the pump is at rest, but will begin to fill when the engine is cranking. This keeps the PCOR vented. Flow to fill the accumulator must pass through the orifices in the sequence poppets (see Circuitry Section 2) and is, therefore, very low. After the engine fires, the accumulator will fill completely and de-vent the compensator. If the precharge pressure is low, the accumulator will fill completely at low pressure and will not significantly "soften" the compensator control.

It should be noted that the GOLD CUP® line of pumps does not have centering springs in the rocker cam stroking chambers. If the rocker cam is left on stroke when the engine is shut off, it will likely remain in that position. If it cannot be insured that the pumps will be returned to neutral before shut-off, some means of unloading during starting should be used.

COLD STARTUP

During cold startups, the diesel engine, hydraulic components and hydraulic oil must reach minimum operating temperatures before full power may be used. Full power operation at temperatures below these minimums may damage components and will hasten their eventual failure.

Hydraulic component minimum temperatures are a function of both mechanical strengths and fluid viscosities. At lower temperatures, the fluid and the components in the system should be brought up to temperature at low shaft speeds, low pressure and low cam angles. When the minimum full power viscosity is reached, the speed, pressure and cam angle may then be increased. Consult sales literature for viscosity limitations for GOLD CUP® components.

NEW SYSTEM OR NEW COMPONENT STARTUP

Starting newly assembled systems and new components requires that several precautions be observed. New systems have high levels of contamination introduced during assembly and new components need to "wear in" for a short period before being used at full ratings. In order to prevent premature failures the following precautions should be followed:

1. Clean reservoir of all weld slag, sand and loose material (see Cleaning Procedures section).
2. Flush all hoses, tubes, and pipes.
3. Double check all circuits for proper assembly.
4. Fill reservoir with filtered oil.
5. Fill pump case full with filtered oil.
6. Install pressure gages on case, replenishment and system pressure gage ports.
7. Set pump displacement to zero.
8. Set the pressure compensator override or system reliefs to 500 psi, 34,4 bar or less.
9. Start the unit and immediately shut it down, or crank the engine without starting for 15 seconds. Check for leaks.
10. If possible, start the unit and run at 1500 rpm or less. If replenishment pressure fails to rise to 200 psi, 13,8 bar within 30 seconds shut down; otherwise idle for 15 minutes, slowly stroke the pump in both directions to purge air from the lines. If replenishment pressure drops off during stroking, limit maximum displacement until the system purges itself of air. Make sure brakes are released so motors will rotate.
11. Run system at 50% stroke and 50% pressure if possible for 15 minutes.
12. Run system at 75% stroke and pressure and 75% rated speed if possible for 15 minutes.
13. If possible, run the system for a few hours at 75% rated speed and pressure until temperature stabilizes.

The above steps for starting a new system or a new pump at very low pressure may need to be modified to fit the system. Note: It is not good practice to run in a new pump at very low pressure and high speed because of lack of lubrication from low internal leakage.

SYSTEM FILTRATION

The GOLD CUP® series pumps are equipped to accept an external filter for filtering charge pump flow. In 6.0, 7.25, 8.0, 24 and 30 in³/rev. pumps the external filter loop is at servo pressure while in the 11 and 14 in³/rev. units it is at replenishing pressure. (See the Circuitry Section 2 for further details). It is recommended that this optional filter loop be utilized in all installations to insure that the cleanest possible oil is introduced to the loop. This filter must be equipped with a bypass to prevent loss of charge flow and should have a dirt alarm to indicate element change requirements.

Return filters installed in the drain lines will remove contaminants before they can enter the reservoir. If other systems draw from the same reservoir, all returns should be filtered.

Filter micron sizes should be chosen to keep the hydrostatic loop to a cleanliness level which meets or exceeds NAS 1638 Class 8 for particle sizes larger than 15 micron and NAS 1638 Class 9 for particles smaller than 15 micron.

For reference, these limits are as follows:

COMPARISON OF SOLID CONTAMINATION CLASSIFICATION SYSTEMS

NATIONAL AEROSPACE STANDARD (NAS) 1638

		CLASS													
		00	0	1	2	3	4	5	6	7	8	9	10	11	12
PARTICLE SIZE RANGE	5-15 µm	125	250	500	1,000	2,000	4,000	8,000	16,000	32,000	64,000	128,000	256,000	512,000	1,024,000
	15-25 µm	22	44	89	178	356	712	1,425	2,850	5,700	11,400	22,800	45,600	91,200	182,000
	25-50 µm	4	8	16	32	63	126	253	506	1,012	2,025	4,050	8,100	16,200	32,400
	50-100 µm	1	2	3	6	11	22	45	90	180	360	720	1,440	2,880	5,760
	>100 µm	0	0	1	1	2	4	8	16	32	64	128	256	512	1,024
MAXIMUM PARTICLES	>5 µm	152	304	609	1,217	2,432	4,864	9,731	19,462	38,924	77,849	155,698	311,396	622,792	1,245,584
	>15 µm	27	54	109	217	432	864	1,731	3,462	6,924	13,849	27,698	55,396	110,792	221,584

ISO:DIS 4406; SAE J1165

		ISO SOLID CONTAMINANT CODE															
		8/5	9/6	10/7	11/8	12/9	13/10	14/11	15/12	16/13	17/14	18/15	19/16	20/17	21/18	22/19	
MAXIMUM PARTICLES	>5 µm	250	500	1,000	2,000	4,000	8,000	16,000	32,000	64,000	130,000	250,000	500,000	1,000,000	2,000,000	4,000,000	
	>15 µm	32	64	130	250	500	1,000	2,000	4,000	8,000	16,000	32,000	64,000	130,000	250,000	500,000	

CLEANING PROCEDURES

Perhaps the leading causes of premature component failure can be traced to improper cleaning procedures in new systems. To reduce the incidence of premature failure, procedures should be drawn up and followed which will insure that all contaminants introduced during manufacture and assembly are removed. There are three periods during assembly and manufacturing which require attention when specifying these procedures:

1. After manufacture of components
2. During assembly of the system
3. After startup of the new system

As components are manufactured, contaminants are introduced from welding, machining and the environment. After manufacturing, components should be thoroughly cleaned prior to being placed in inventory. Welded assemblies which will carry or hold hydraulic fluids (tube assemblies, reservoirs, manifolds, etc.) should be pickled to remove scale, slag and splatter from all surfaces. Large weldments such as reservoirs which are too large for pickling tanks may be abrasive blasted if care is taken to ensure removal of **all** residue and blasting media.

Flushing of welded assemblies is not recommended as the sole cleaning procedure as welding residues will not be removed effectively. Any residues left after cleaning will be loosened and released by stresses caused by pressure and heat. Hose assembly should be flushed with clean solvents after assembly to remove residue from cutting.

After cleaning, all assemblies should be protected from corrosion and capped or sealed before storage.

During machine assembly, sub-assemblies should be flushed to remove contaminant introduced during the assembly process. Caps and seals should be left on components, tubes, and hoses until just prior to making connections.

When filling reservoirs, the fluid should be pumped through a series of filters to remove contaminants. Filters for filling and flushing systems should be much larger and finer than those used in the machine itself. In many cases, filter cartridge life on filling and flushing systems can be extended by cascading filters with flow progressing through coarse to fine filtration.

During initial startup of new systems, extra temporary filtration added will help prevent component damage. In closed circuit hydrostatic transmission circuits, adding filters to the main loop will greatly expedite cleanup. After a system has cleaned up and prior to shipment, the loop filters may be removed.



Just prior to shipment, all filter elements should be changed so the customer receives a machine with new elements. Specific maintenance instructions should be provided to machine owners which detail filter and fluid change intervals.

SHAFT TYPE SELECTION

There are two standard shaft configurations available in the GOLD CUP® series. They are:

(2) SAE spline

(3) SAE key

Selection of the proper type shaft is an important consideration in applying GOLD CUP® pumps and motors. Keyed and splined shafts are unique in their design and application and may not be freely interchanged one for the other.

In general, keyed shafts are applied when a device is to be firmly and rigidly affixed to the shaft. These devices include pulleys, sprockets, fans, one-half of flexible couplings, etc. The shaft itself must be rigidly supported by the bearings in the unit and the device attached to the shaft must be solely supported by the shaft. If the device connected to the shaft cannot be rigidly affixed to the shaft or supported solely by it, a keyed shaft should not be used.

Splined shafts are to be applied whenever the shaft is to be coupled directly to a supported receiver. These types of devices include gear boxes, PTO drive pads, brake assemblies, etc. Splined shafts should also be used when two rigidly supported shafts are connected by a floating coupling. An example is when a thru-splined coupler is used to connect two splined shafts.

Keyed shafts in GOLD CUP® pumps are limited in the number of pressure cycles the pump is subjected to. Please consult the appropriate sales bulletin for these limitations.

If these limits will be exceeded splined shafts must be used. Because in many cases these applications would normally call for use of keyed shafts, special consideration must be taken in the selection of the coupling. Both shafts must be rigidly supported and properly aligned. If the other shaft is splined, a thru-splined sleeve may be slipped over both shafts. If the other shaft is keyed, a semi-rigid coupling must be used. This type of coupling mounts rigidly on the keyed shaft and allows the splined half to float. The floating half is then splined to slip over the splined shaft. **Do not set screw the floating half to the splined shaft.**

APPLYING SPLINED SHAFTS

In all applications the pitch diameter of the mating splines must be square to the mounting surface within .001" per inch, .001mm per millimeter of shaft extension. Angular misalignment should be measured over pins at 180° rotation, for two points on the shaft 90° apart.

Female splines mating to Parker splines must be hardened to within 27 to 45 Rc to reduce wear and the splined interface must be lubricated with high quality gear lubricant. For shafts that will not be bathed continually in lubricant we recommend lubrication with lithium molydisulfide grease.

All female splines mating to Parker shafts must conform to SAE-J498B (1971). This is known as a Flat Root Side Fit.

APPLYING KEYED SHAFTS

When applying keyed shafts care must be taken to insure that the key is fully engaged between both the shaft and the receiver. The key then must be set-screwed in place to prevent pounding of the key. It is highly recommended that the keys be heat treated to between 27 and 34 Rockwell C. Both shafts, when using a flexible coupling, must be aligned to the coupling manufacturer's specifications.

Proper adherence to these specifications will insure maximum life of the shaft and shaft bearings.

PERFORMANCE CURVES

Series 6
 Variable volume pump with 1.07 in³/rev.,
 17,5 cm³/rev. auxiliary pump

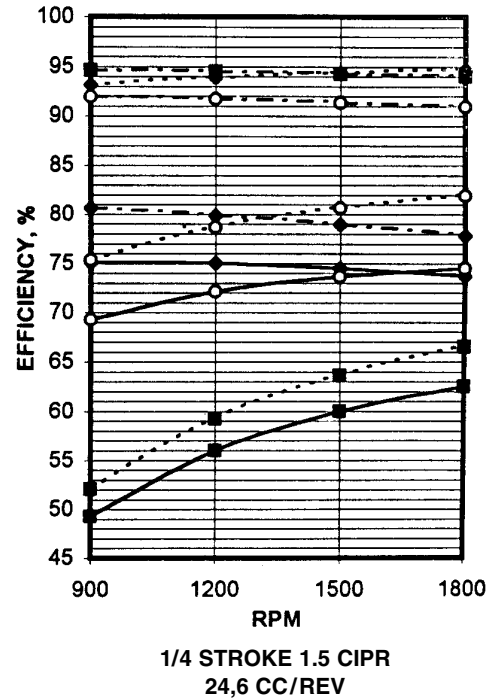
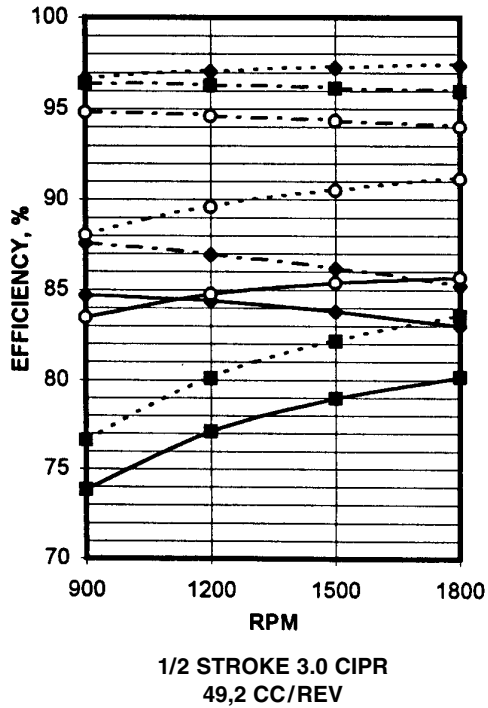
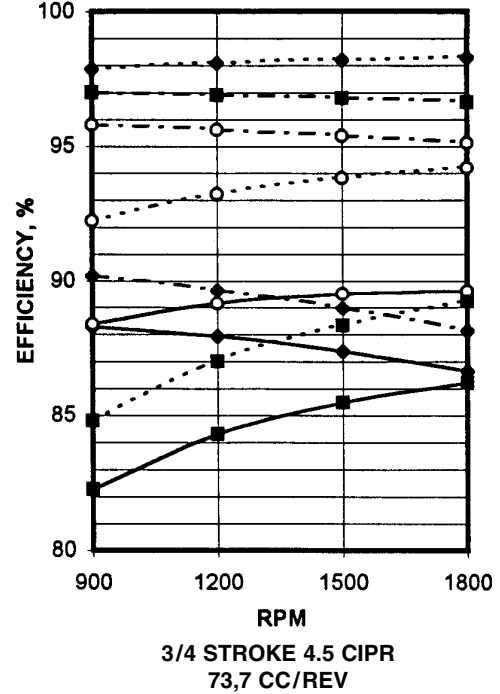
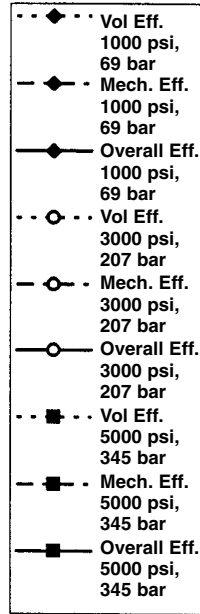
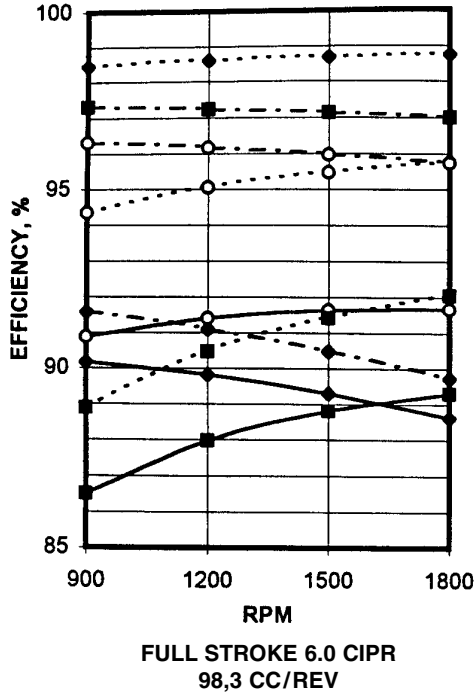

PERFORMANCE CURVES

Series 6
 Variable volume motor

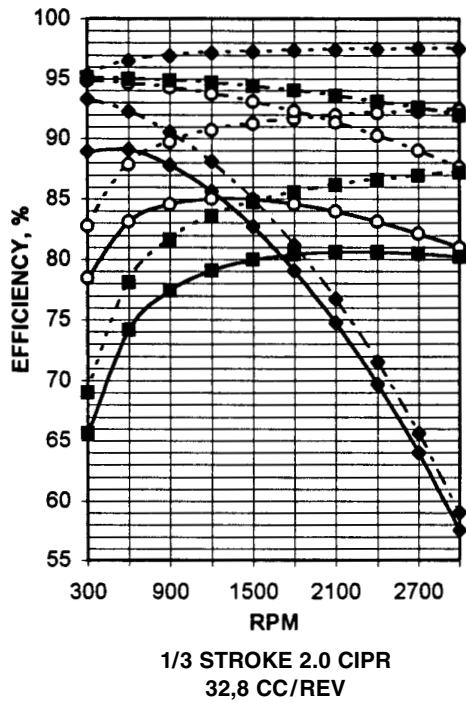
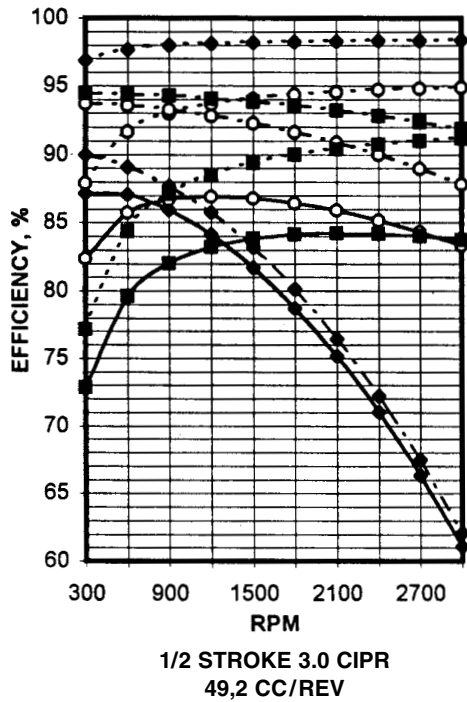
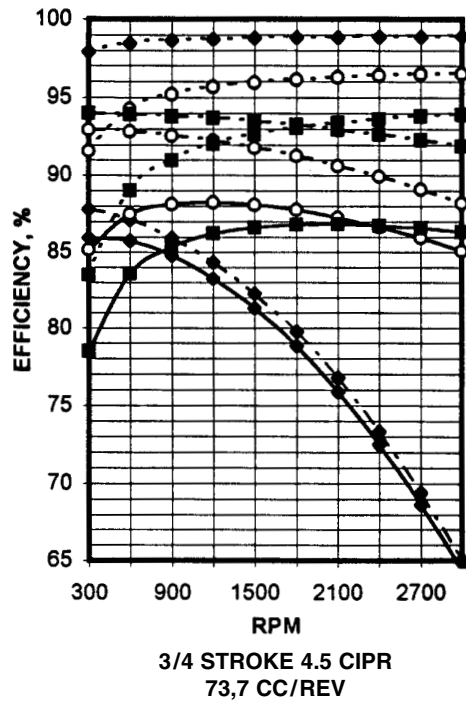
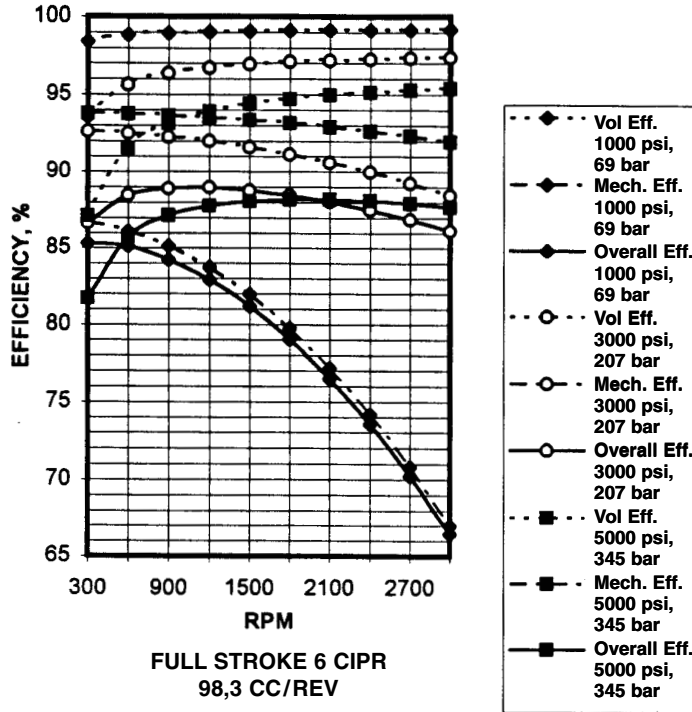

PERFORMANCE CURVES

Series 7
 Variable volume pump with 1.07 in³/rev.,
 17,5 cm³/rev. aux. pump

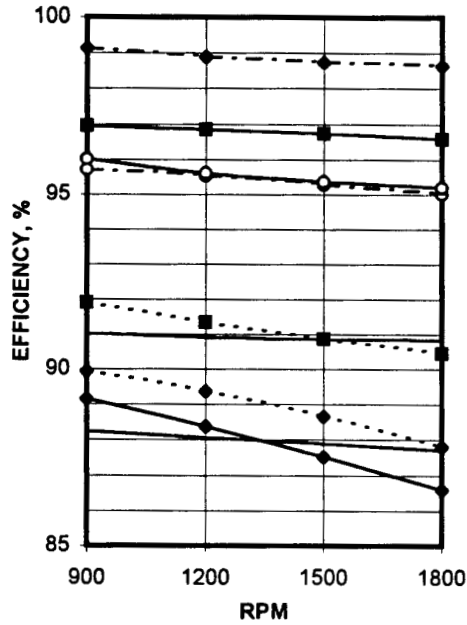

FULL STROKE 7.25 CIPR
118,8 CC/REV

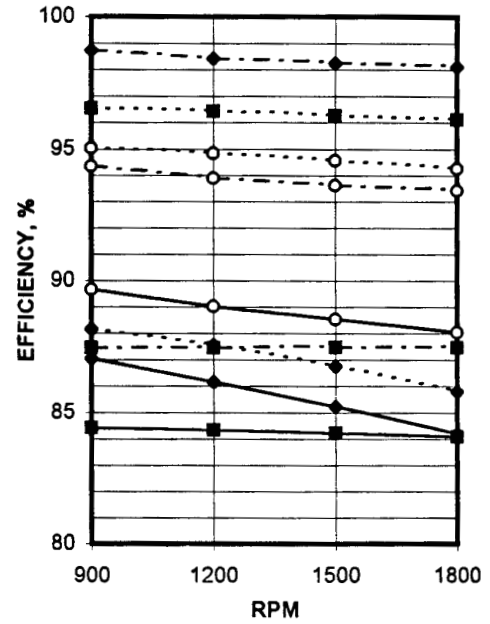
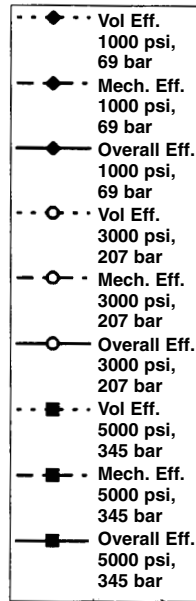

3/4 STROKE 5.44 CIPR
89,1 CC/REV

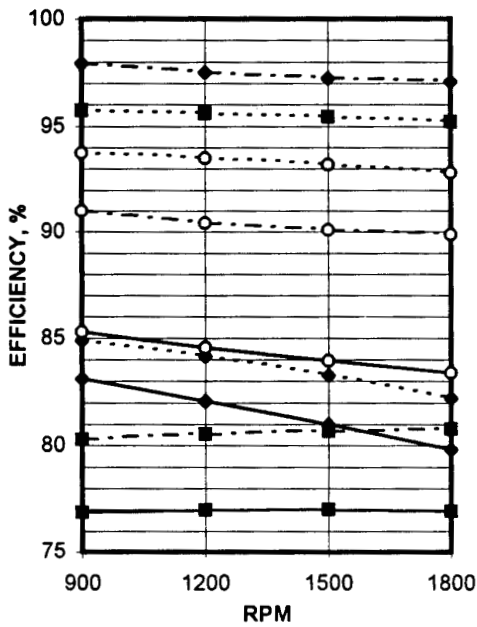

1/2 STROKE 3.62 CIPR
59,4 CC/REV

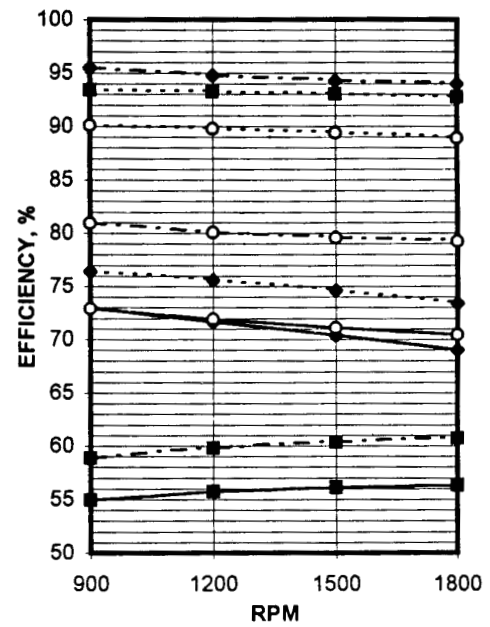

1/4 STROKE 1.81 CIPR
29,7 CC/REV

PERFORMANCE CURVES

Series 7
 Variable volume motor

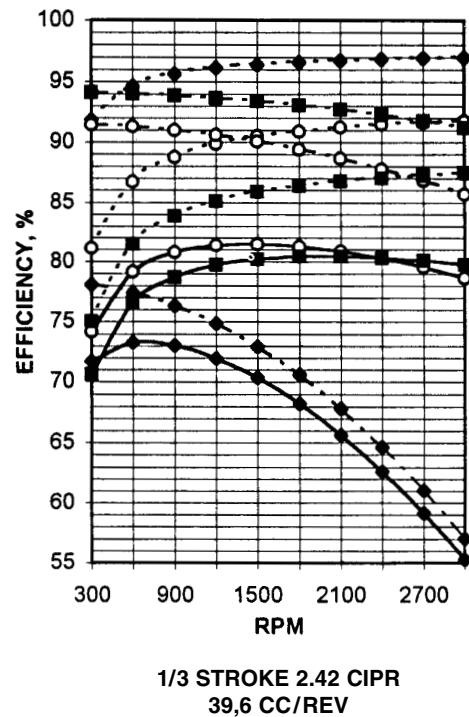
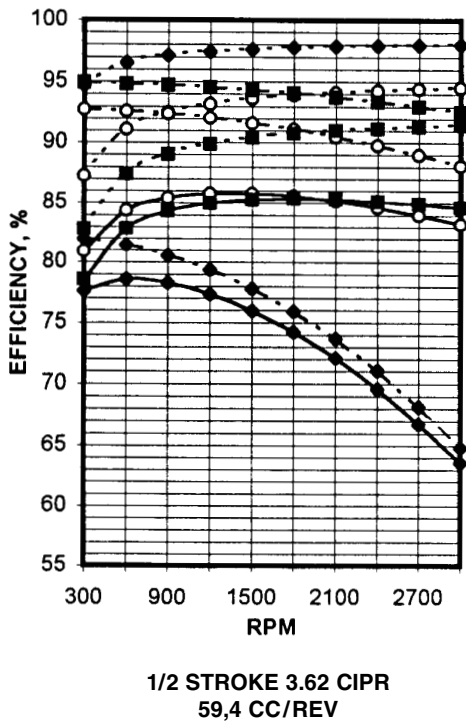
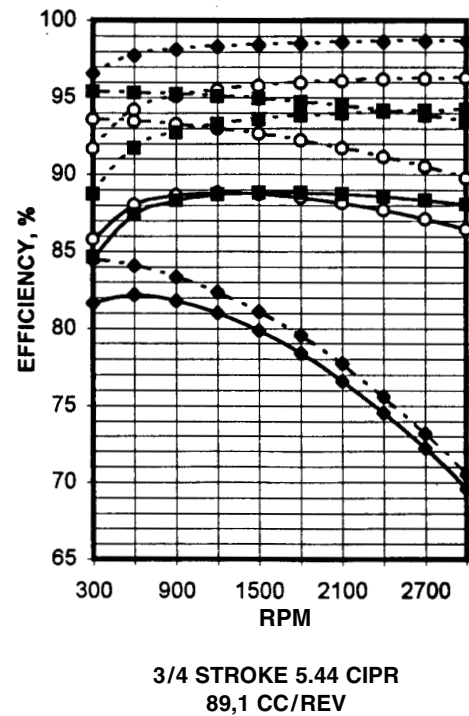
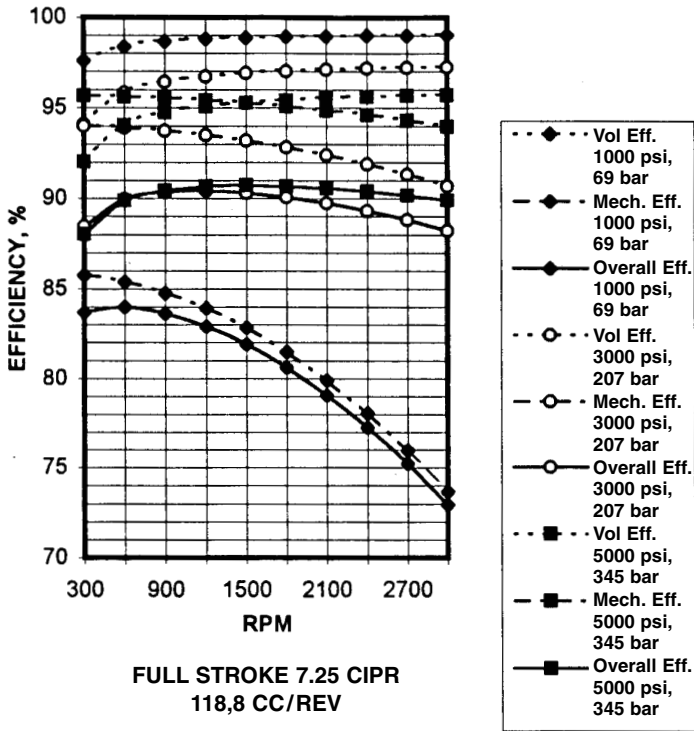

PERFORMANCE CURVES

Series 8
 Variable volume pump with 1.07 in³/rev.,
 17,5 cm³/rev. aux. pump

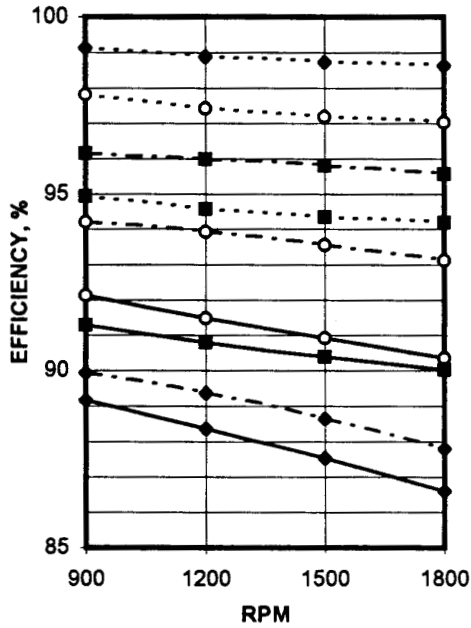

FULL STROKE 8.0 CIPR
 131,1 CC/REV

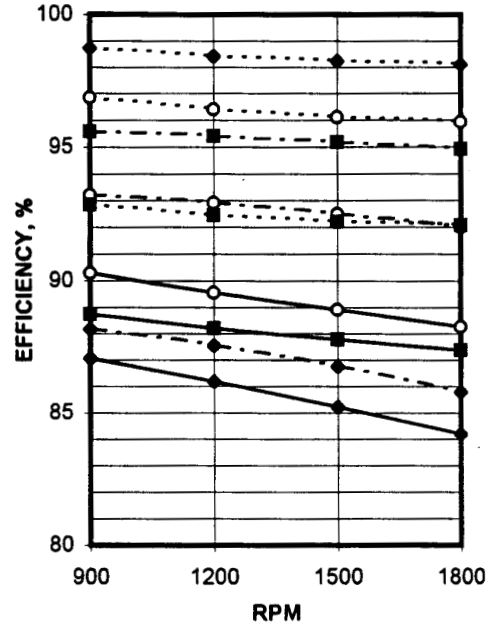
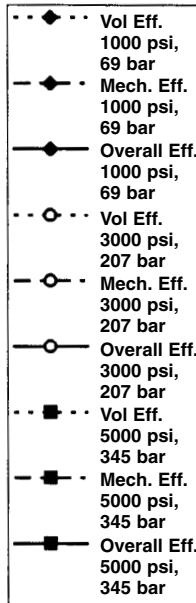

3/4 STROKE 6.0 CIPR
 98,3 CC/REV

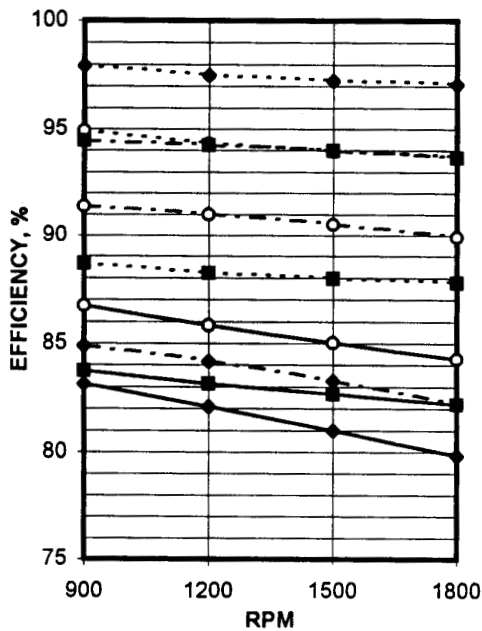

1/2 STROKE 4.0 CIPR
 65,6 CC/REV

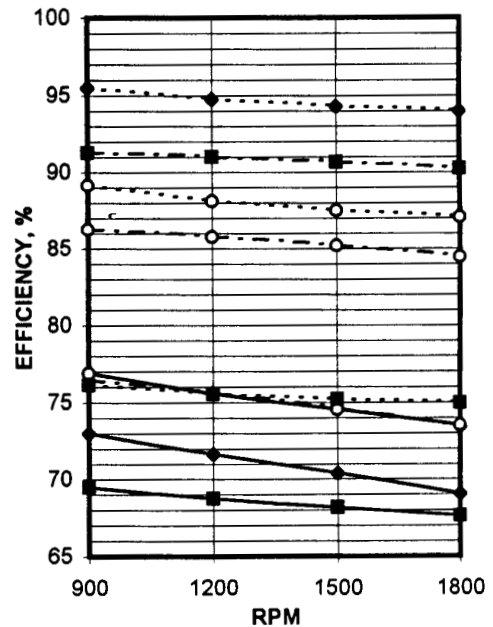

1/4 STROKE 2.0 CIPR
 32,8 CC/REV

PERFORMANCE CURVES

Series 11
 Variable volume pump with 2.14 in³/rev.,
 35 cm³/rev. aux. pump

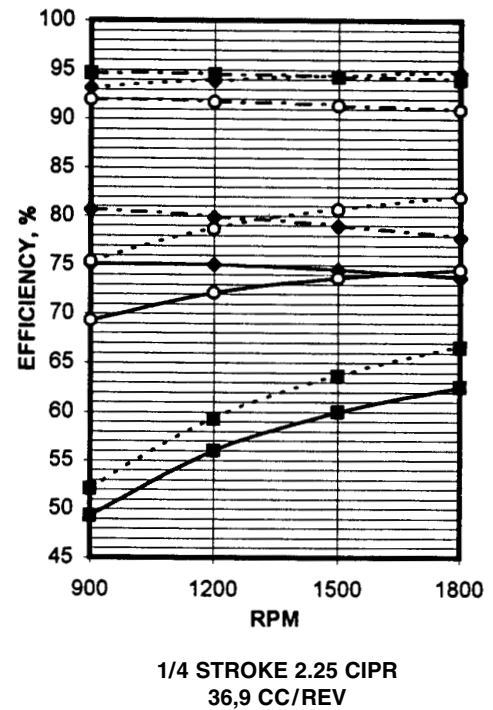
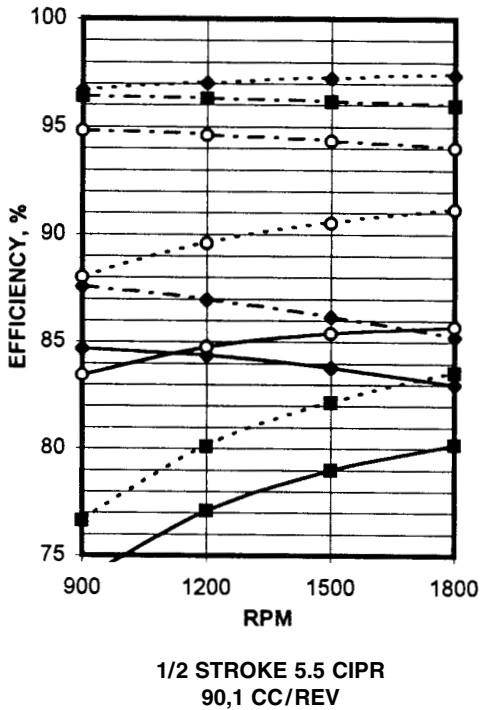
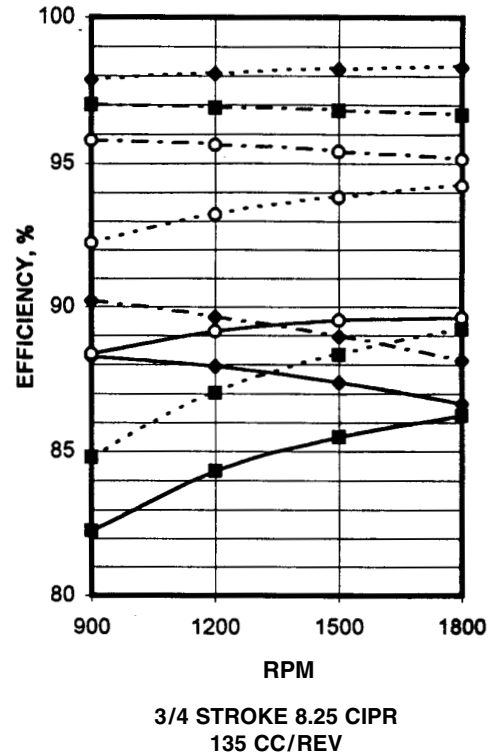
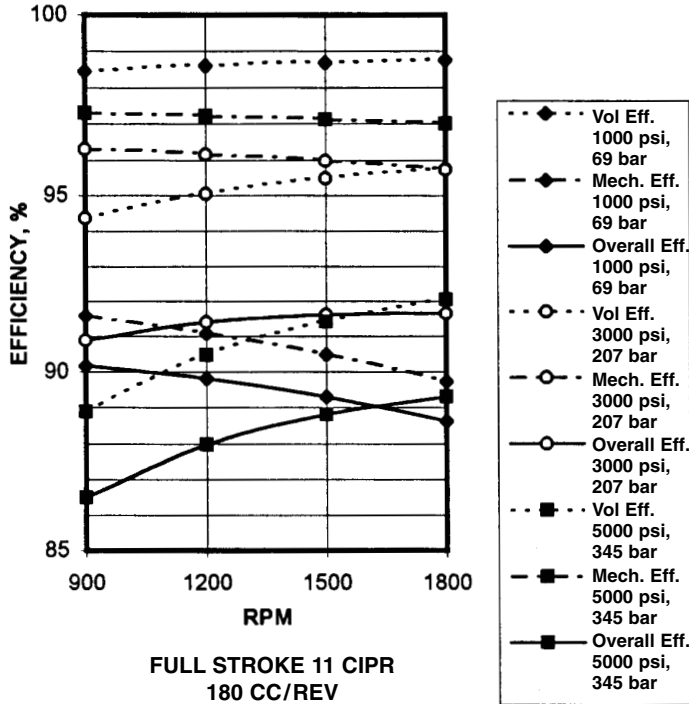

PERFORMANCE CURVES

Series 11
 Variable volume motor

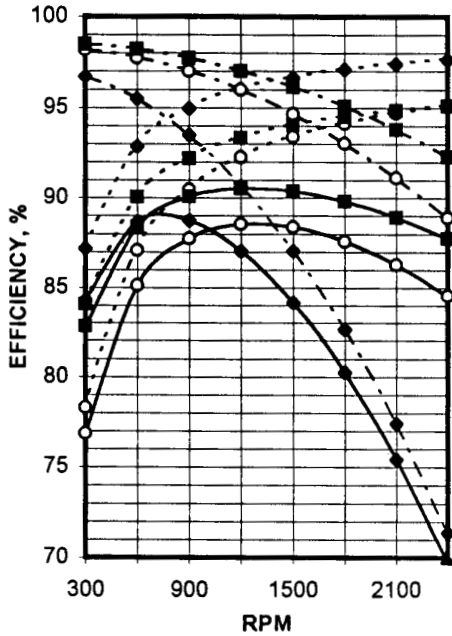

FULL STROKE 11 CIPR
180 CC/REV

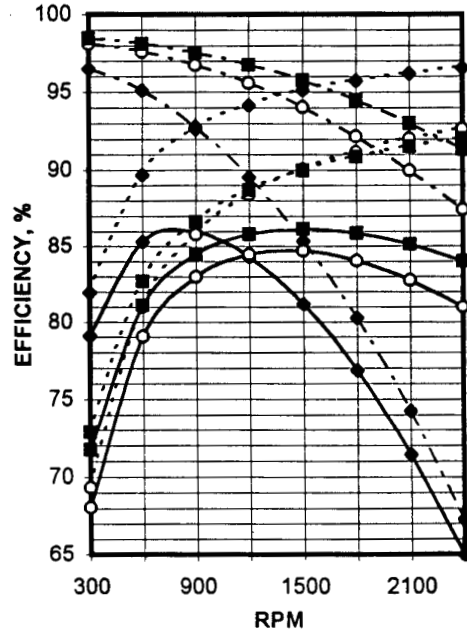
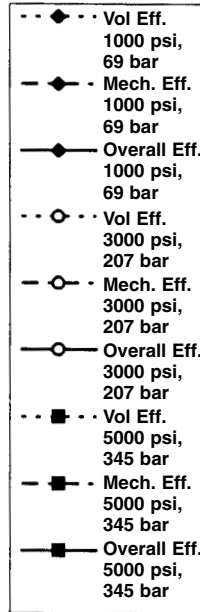

3/4 STROKE 8.25 CIPR
135 CC/REV

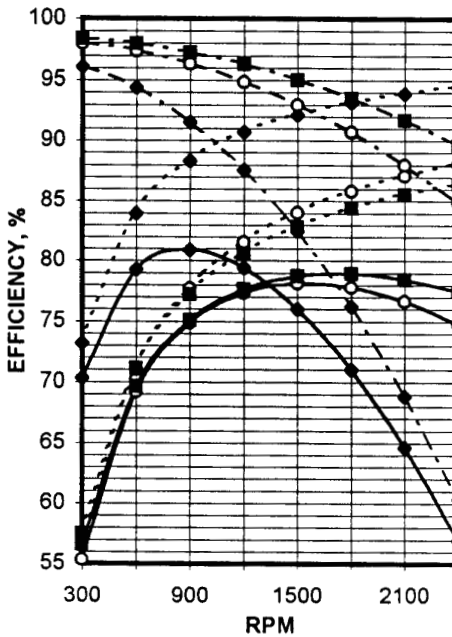

1/2 STROKE 5.5 CIPR
90,1 CC/REV

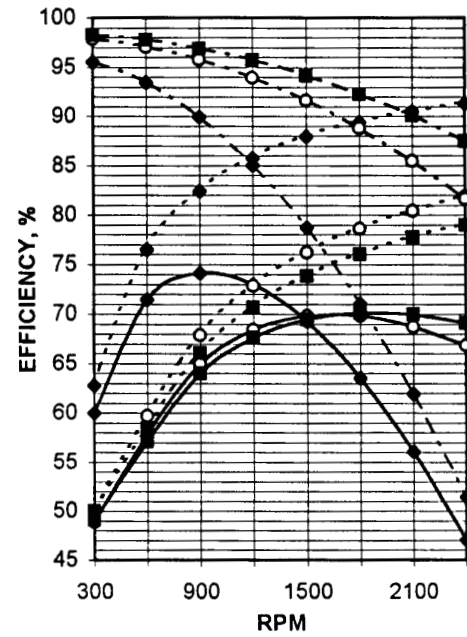

1/3 STROKE 3.67 CIPR
60,1 CC/REV

PERFORMANCE CURVES

Series 14
 Variable volume pump with 2.14 in³/rev.,
 35 cm³/rev. aux. pump

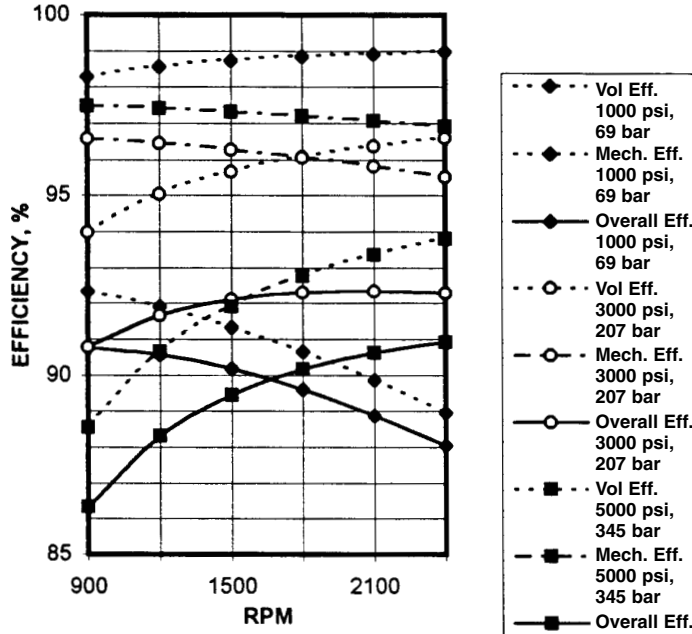

FULL STROKE 14 CIPR
 229,4 CC/REV

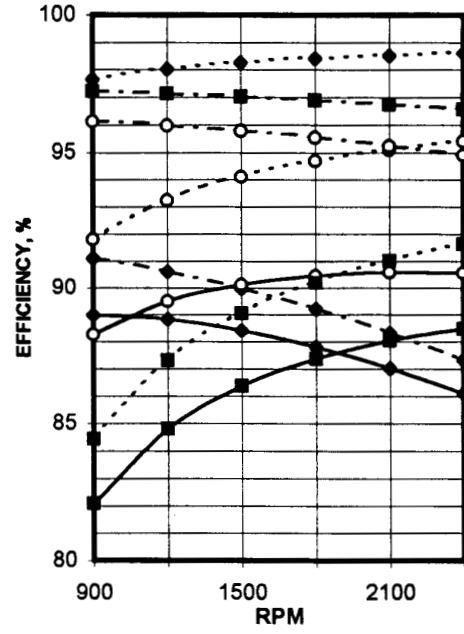

3/4 STROKE 10.5 CIPR
 172 CC/REV

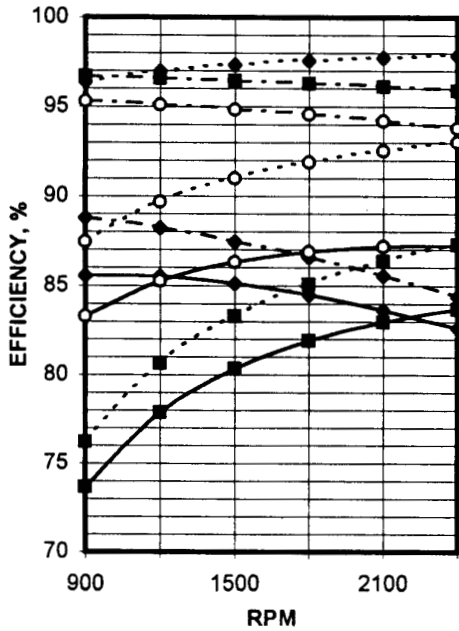

1/2 STROKE 7 CIPR
 114,7 CC/REV

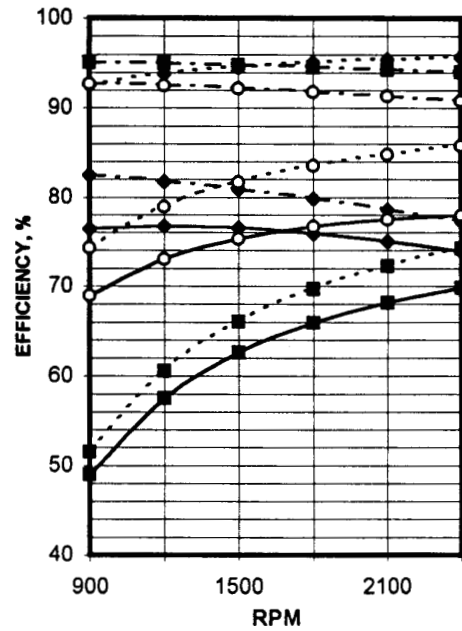

1/4 STROKE 3.5 CIPR
 57,4 CC/REV



PERFORMANCE CURVES

Series 14
 Variable volume motor

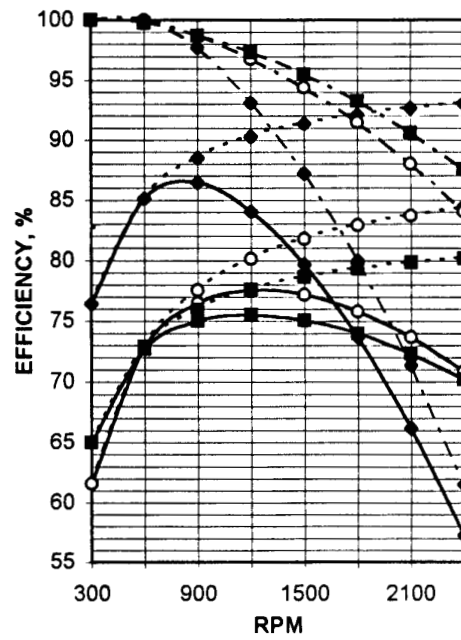
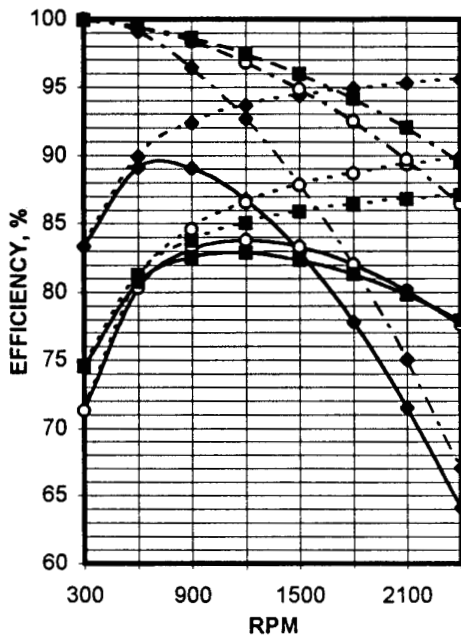
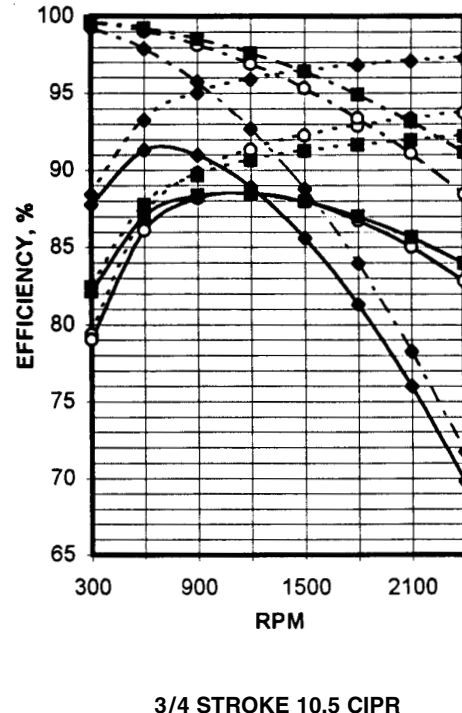
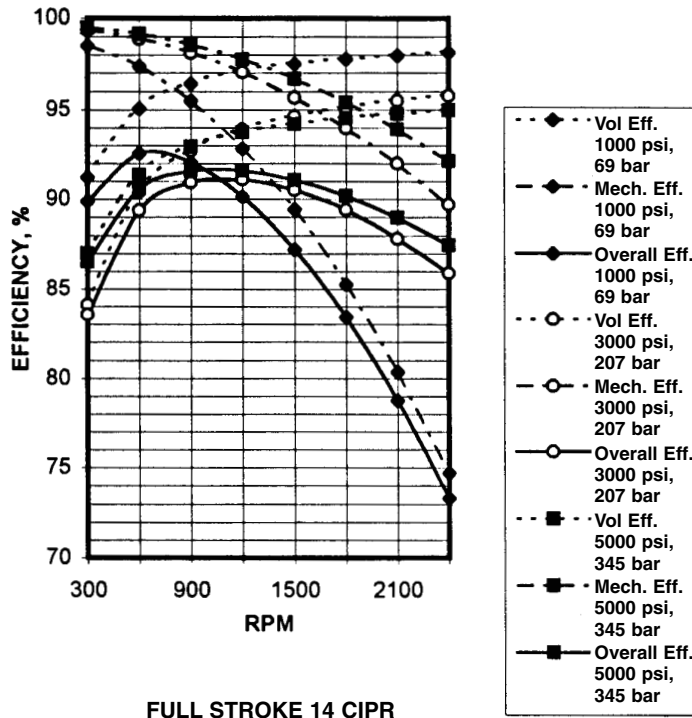

PERFORMANCE CURVES

Series 24
 Variable volume pump with 2.81 in³/rev.,
 46 cm³/rev. aux. pump

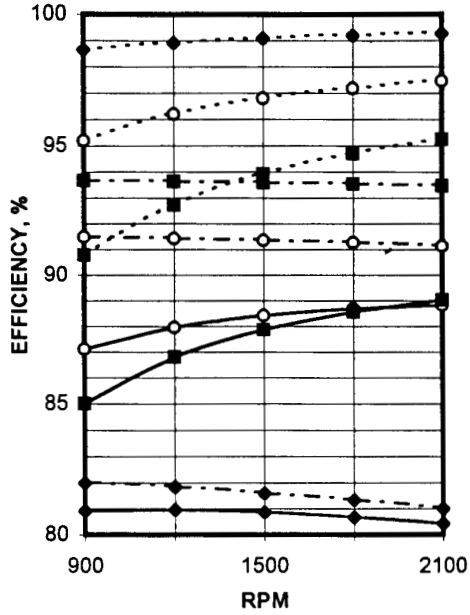

FULL STROKE 24.66 CIPR
404 CC/REV

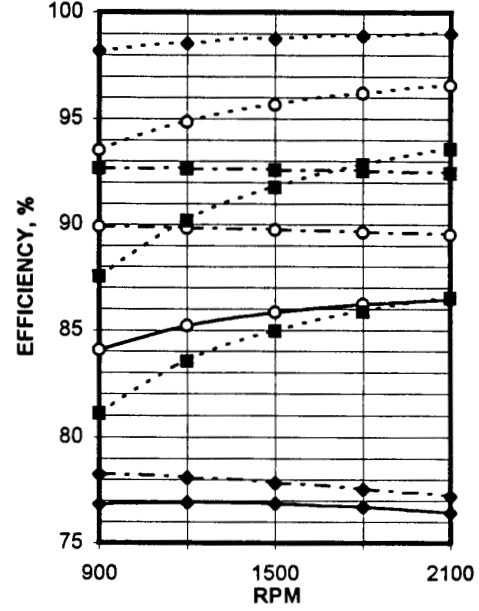
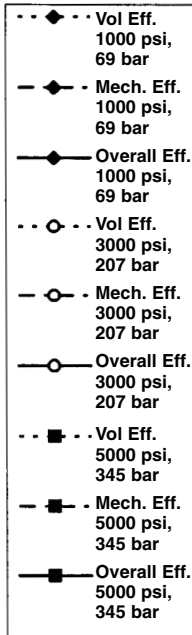

3/4 STROKE 18.44 CIPR
303 CC/REV

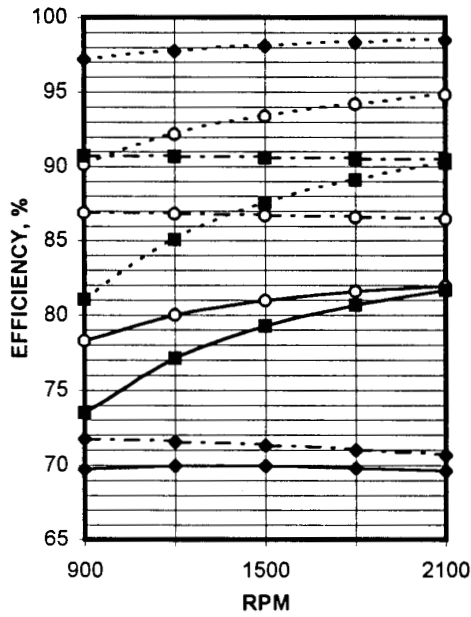

1/2 STROKE 12.33 CIPR
202 CC/REV

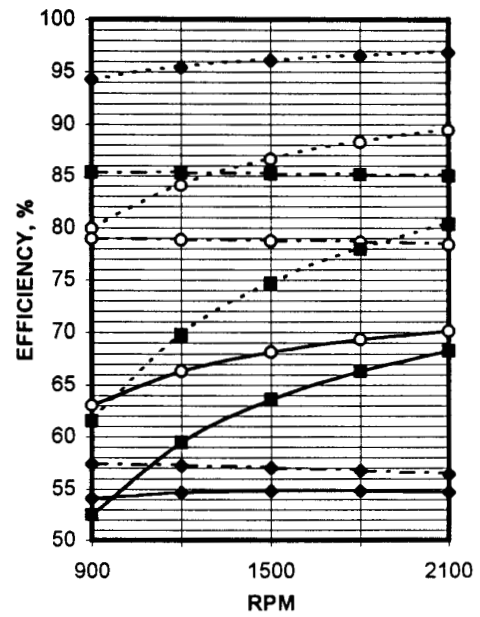

1/4 STROKE 6.16 CIPR
101 CC/REV



PERFORMANCE CURVES

Series 24
 Variable volume motor

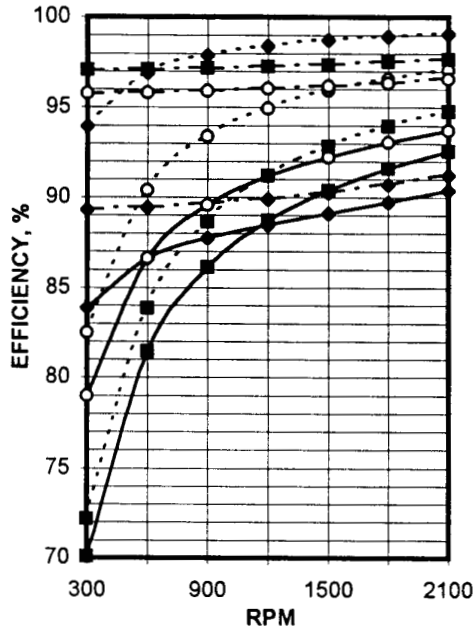

FULL STROKE 24.66 CIPR
404 CC/REV

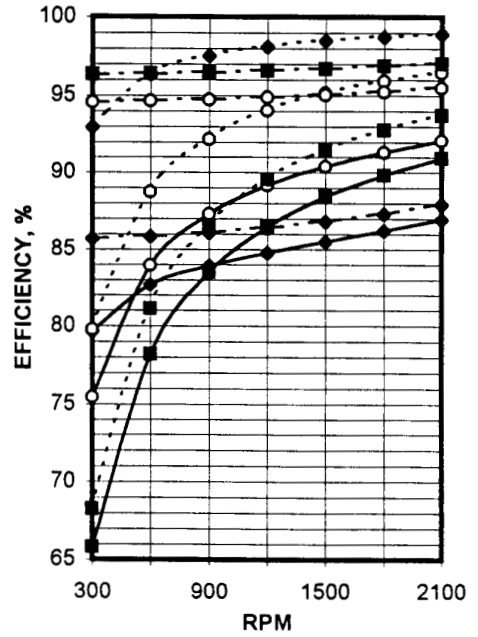
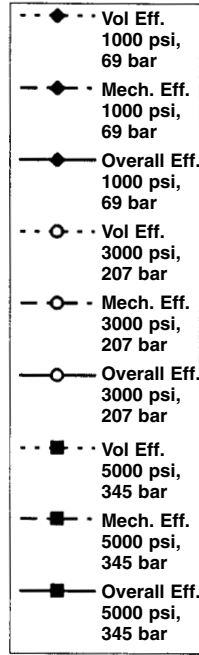

3/4 STROKE 18.5 CIPR
303 CC/REV

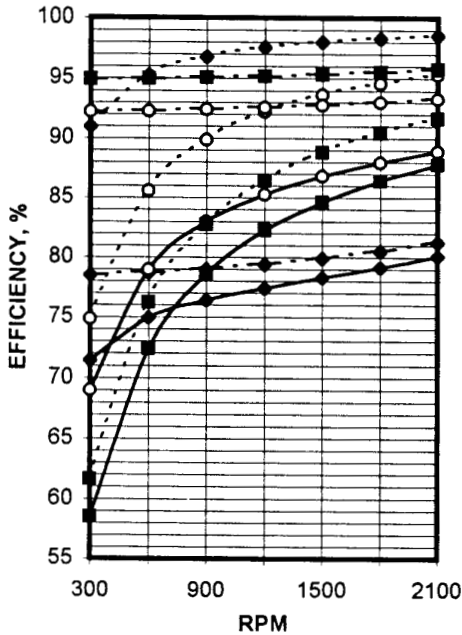

1/2 STROKE 12.33 CIPR
202 CC/REV

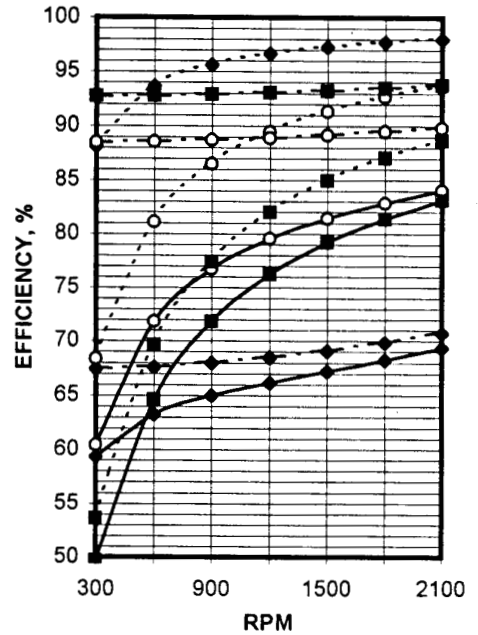

1/3 STROKE 8.22 CIPR
135 CC/REV

PERFORMANCE CURVES

Series 30
 Variable volume pump with 2.81
 in³/rev., 46 cm³/rev. aux. pump

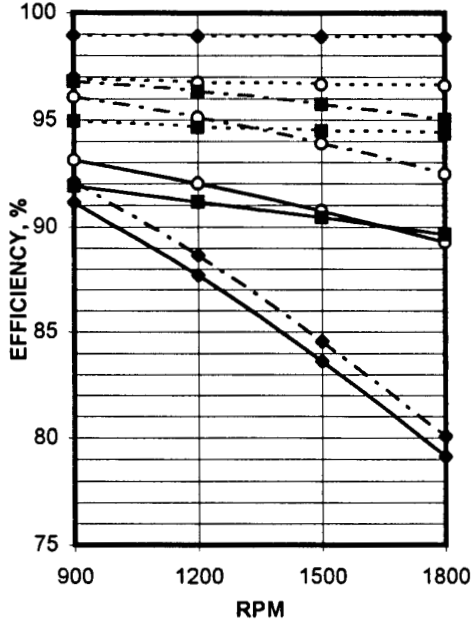

FULL STROKE 30.6 CIPR
501,4 CC/REV

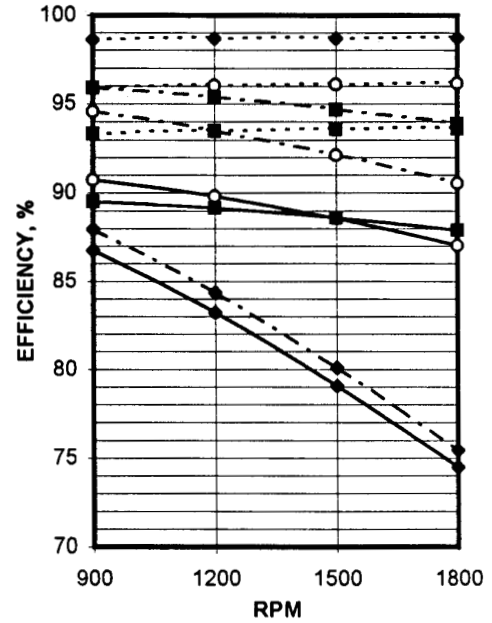

3/4 STROKE 23 CIPR
376 CC/REV

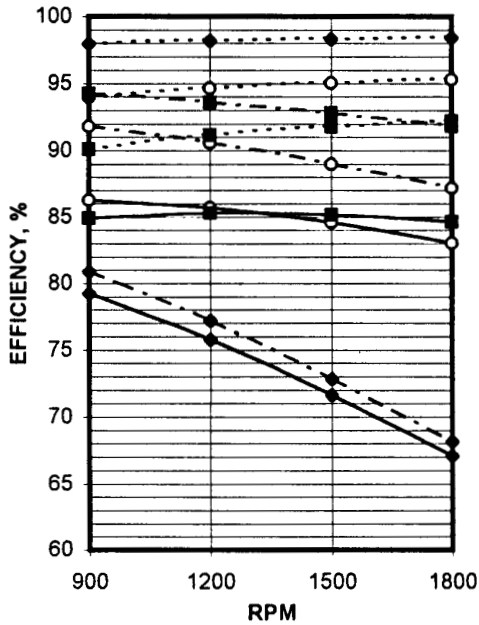

1/2 STROKE 15.3 CIPR
250,7 CC/REV

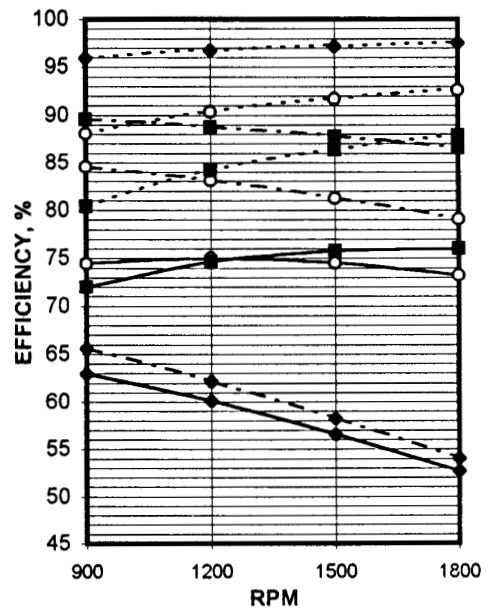

1/4 STROKE 7.6 CIPR
125,4 CC/REV



CONVERSION FACTORS

DEFINITION & UNIT

displacement	$\text{in}^3/\text{rev} \times 16.387 = \text{cm}^3/\text{rev}$	$\text{cm}^3/\text{rev} \times 0.06102 = \text{in}^3/\text{rev}$
flow	$\text{gpm} \times 3.78 = \text{L}/\text{min}$	$\text{L}/\text{min} \times 0.2642 = \text{gpm}$
power	$\text{hp} \times 0.7457 = \text{kW}$	$\text{kW} \times 1.341 = \text{hp}$
torque	$\text{lb-ft} \times 1.3567 = \text{Nm}$	$\text{Nm} \times 0.7376 = \text{lb-ft}$
pressure	$\text{lbs}/\text{in}^2 \text{ (psi)} \times 0.06895 = \text{bar}$ $\text{lbs}/\text{in}^2 \text{ (psi)} \times 6.895 = \text{kPa}$	$\text{bar} \times 14.50 = \text{lbs}/\text{in}^2 \text{ (psi)}$ $\text{kPa} \times 0.1450 = \text{lbs}/\text{in}^2 \text{ (psi)}$
weight	$\text{lb} \times 0.4536 = \text{kg}$	$\text{kg} \times 2.205 = \text{lbs}$
force	$\text{lb} \times 4.448 = \text{N}$	$\text{N} \times 0.2248 = \text{lbs}$
volume	$\text{in}^3 \times 16.387 = \text{cm}^3$	$\text{cm}^3 \times 0.06102 = \text{in}^3$
area	$\text{in}^2 \times 6.452 = \text{cm}^2$	$\text{cm}^2 \times 0.1550 = \text{in}^2$
length	$\text{in} \times 25.4 = \text{mm}$	$\text{mm} \times 0.03937 = \text{in}$
temperature	$\frac{\text{degree F}-32}{1.8} = \text{°C}$	$1.8 \times \text{C}+32 = \text{°F}$
viscosity	$\text{cSt} \times 1.0 = \text{mm}^2/\text{sec}$ $\text{SSU} = \text{cSt} \times 4.25 + 14$	$\text{mm}^2/\text{sec} \times 1.0 = \text{cSt}$ $20 \text{ cSt} = 99 \text{ SSU}$

FLUID POWER FORMULAS

Pump input torque	lbs. in.	$\frac{\text{pressure}(\text{psi}) \times \text{displacement} (\text{in}^3/\text{rev})}{2\pi \times \text{mech. eff.}}$
Pump input power	hp	$\frac{\text{rpm} \times (\text{in}^3/\text{rev}) \times (\text{psi})}{395934 \times \text{overall eff.}}$
Pump output flow	U.S. gpm	$\frac{\text{rpm} \times (\text{in}^3/\text{rev}) \times \text{volumetric eff.}}{231}$
Fluid motor speed	rpm	$\frac{231 \times \text{flow rate}(\text{U.S. gpm}) \times \text{volumetric eff.}}{\text{displacement} (\text{in}^3/\text{rev})}$
Fluid motor torque	lbs. in.	$\frac{\text{pressure}(\text{psi}) \times \text{displacement} (\text{in}^3/\text{rev}) \times \text{mech. eff.}}{2\pi}$
Fluid motor power	hp	$\frac{\text{rpm} \times (\text{in}^3/\text{rev}) \times (\text{psi}) \times \text{overall eff.}}{395934}$
(metric)		
Pump input torque	Nm	$\frac{\text{pressure}(\text{bar}) \times \text{displacement} (\text{cm}^3/\text{rev})}{20\pi \times \text{mech. eff.}}$
Pump input power	kW	$\frac{\text{rpm} \times (\text{cm}^3/\text{rev}) \times (\text{bar})}{600000 \times \text{overall eff.}}$
Pump output flow	Lpm	$\frac{\text{rpm} \times (\text{cm}^3/\text{rev}) \times \text{volumetric eff.}}{1000}$
Fluid motor speed	rpm(min ⁻¹) (tr/mn)	$\frac{1000 \times \text{flow rate} (\text{Lpm}) \times \text{volumetric eff.}}{\text{displacement} (\text{cm}^3/\text{rev})}$
Fluid motor torque	Nm	$\frac{\text{pressure}(\text{bar}) \times \text{displacement} (\text{cm}^3/\text{rev}) \times \text{mech. eff.}}{20\pi}$
Fluid motor power	kW	$\frac{\text{rpm} \times (\text{cm}^3/\text{rev}) \times (\text{bar}) \times \text{overall eff.}}{600000}$

Section 6 - Pump Ordering Code

GOLD CUP® Series - Application Manual
Piston Pumps & Motors

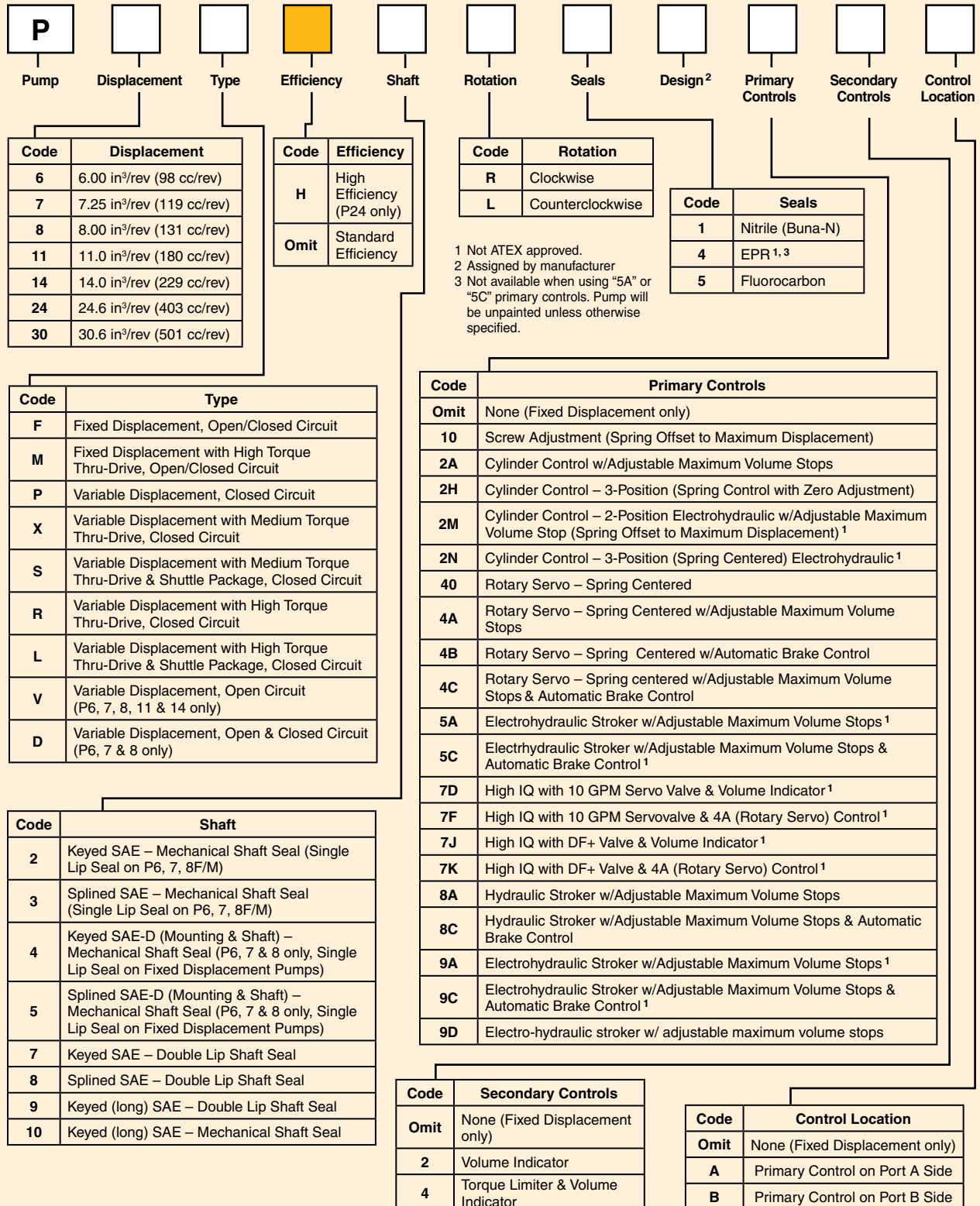

= Omit if not required



Section 6 - Pump Ordering Code

GOLD CUP® Series - Application Manual
Piston Pumps & Motors

Control & Displacement Features		
Control	Code	Control Feature
2M* & 2N*	00	CETOP3, NG6 Valve, 110AC/60Hz with Hirschmann Connector ¹
	01	CETOP3, NG6 Valve, 12VDC with Hirschmann Connector ¹
	02	CETOP3, NG6 Valve, 240VAC/50Hz with Hirschmann Connector ¹
	03	CETOP3, NG6 Valve, 110VAC/60Hz, Wiring Box ¹
	04	CETOP3, NG6 Valve, 12VDC, Wiring Box ¹
	05	CETOP3 (D03, NG6) Interface, No Valve ¹
	06	CETOP3, NG6 Valve, 24VDC with Hirschmann Connector ¹
	07	CETOP3, NG6 Valve, 110VAC/50Hz with Hirschmann Connector ¹
5**	00	With Deadband ¹
	01	Without Deadband ¹
7**	00	Without Manual Override Shutoff ¹
	01	With Manual Override Shutoff ¹ (required for F & K primary options)
8**	00	75-350 PSI (5-24 Bar)
	01	75-435 PSI (5-30 Bar)
	02	100-300 PSI (7-26 Bar)
	03	150-400 PSI (10-28 Bar)
	04	75-250 PSI (5-17 Bar)
9**	00	24VDC
	01	12VDC
All Other	00	None ¹
Pump	Code	Reduced Displacement
P**F & P**M	00	Standard Cam (19°)
	10	P6 with 17° Cam – 5.3 in ³ /rev (87cc/rev) P7 with 17° Cam – 6.4 in ³ /rev (105 cc/rev) P8 with 17° Cam – 7.1 in ³ /rev (116 cc/rev) P11 with 17° Cam – 9.7 in ³ /rev (160 cc/rev) P14 with 17° Cam – 12.5 in ³ /rev (205 cc/rev) P24 with 17° Cam – 22.0 in ³ /rev (360 cc/rev) P30 with 17° Cam – 27.2 in ³ /rev (446 cc/rev)
	20	P6 with 15° Cam – 4.6 in ³ /rev (76 cc/rev) P7 with 15° Cam – 5.6 in ³ /rev (92 cc/rev) P8 with 15° Cam – 6.2 in ³ /rev (102 cc/rev) P11 with 15° Cam – 8.5 in ³ /rev (140 cc/rev) P14 with 15° Cam – 10.9 in ³ /rev (179 cc/rev)
	30	P6 with 13° Cam – 4.0 in ³ /rev (66 cc/rev) P7 with 13° Cam – 4.8 in ³ /rev (79 cc/rev) P8 with 13° Cam – 5.3 in ³ /rev (88 cc/rev)

 = Omit if not required

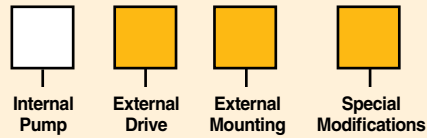

Code	Special Modifications
Omit	None
NP	No Paint ¹
EX	ATEX APPROVED PUMP (May contain additional modifications. Contact tech support.)
M2	Other Special Modification (example: bronze caged barrel bearing for low viscosity fluids, tandem pumps, etc.) ¹

Code	External Mounting
Omit	No External Drive Required
0	No External Pump Mounted
1	External Pump Mounted (must be separately specified) – Requires Special Modification “-M2” ¹
2	ATEX Externally Mounted Pump

Code	External Drive
Omit	None ¹
M	Blanking plate – for P6, 7, 8, 11, 14S/X only
A	SAE-A (SAE 82-2) – P6, 7, 8, 11, 14S/X/R/L/M only
B	SAE-B (SAE 101-2) – P6, 7, 8, 11, 14, 24, 30S/X/R/L/M SAE-B (SAE 101-4) – P11, 14, 24, 30R/L/M
C	SAE-C (SAE 127-2) – P6, 7, 8, 11, 14, 24, 30R/L/M & P24, 30S/X SAE-C (SAE 127-4) – P11, 14, 24, 30R/L/M
D	SAE-D (SAE 152-4) – P11, 14, 24, 30R/L/M only
E	SAE-E (SAE 165-4) – P11, 14, 24, 30R/L/M only
F	SAE-F (SAE 177-4) – P24, 30R/L/M only

Code	Internal Pump
0	1.07 in ³ /rev (17.5 cc/rev) – P6, 7, 8P/S/X/V/D & P11, 14V only** 2.14 in ³ /rev (35 cc/rev) – P11, 14P/S/X only** 2.81 in ³ /rev (46 cc/rev) – P24, 30P/S/X only (standard)**
1	1.61 in ³ /rev (26.4 cc/rev) – P24, 30P/S/X only (auxiliary external replenishing flow required)
2	1.05 in ³ /rev (17.2 cc/rev) – P24, 30P/S/X only (auxiliary external replenishing flow required)
3	3.56 in ³ /rev (58.3 cc/rev) – P24, 30P/S/X only
4	4.84 in ³ /rev (79.3 cc/rev) – P24, 30P/S/X only
5	5.42 in ³ /rev (88.8 cc/rev) – P24, 30P/S/X only
6	6.10 in ³ /rev (100.0 cc/rev) – P24, 30P/S/X only
X	No Internal Pump (standard on P*R/L/F/M)

** Omit code if no external drive is required.

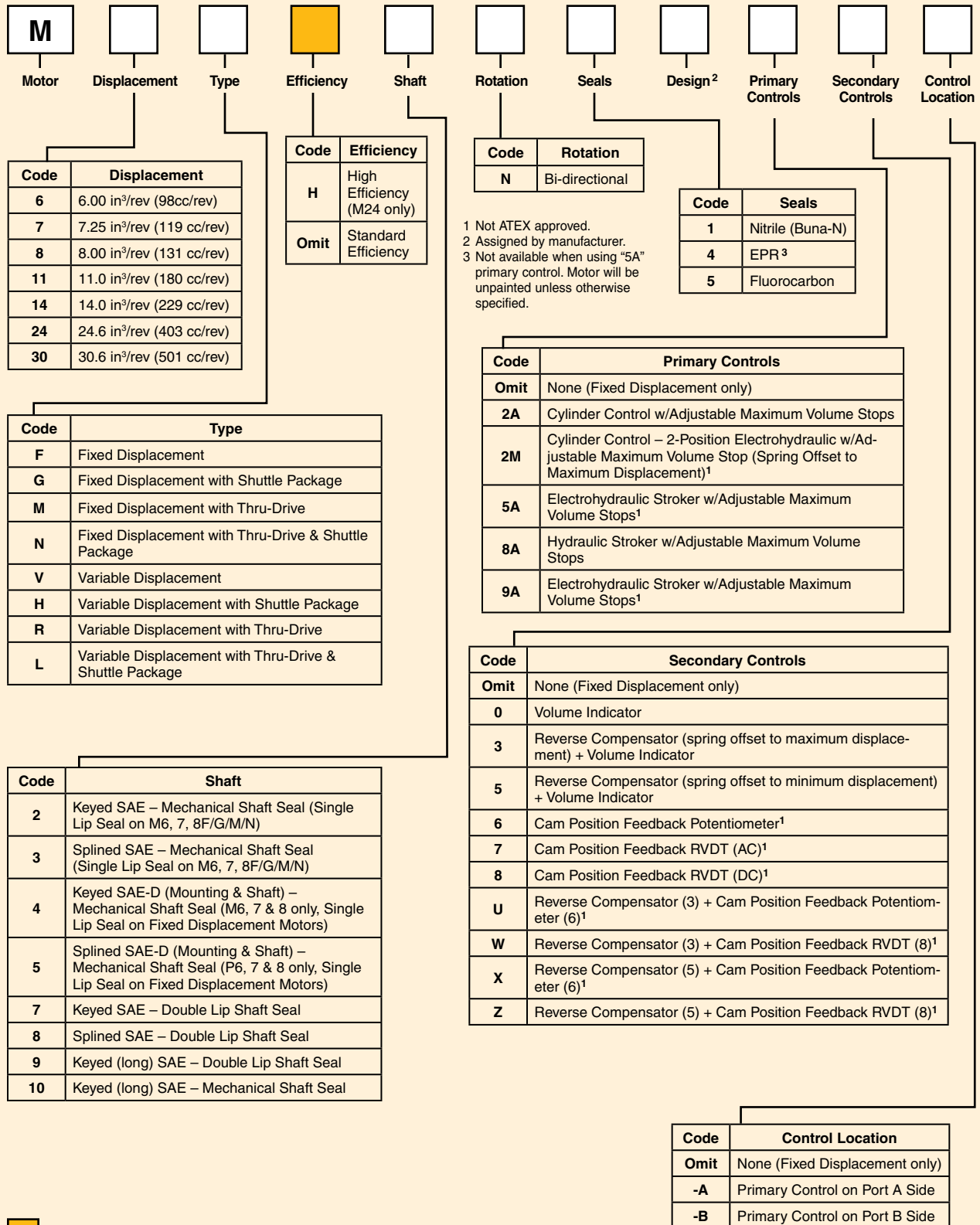

Section 6 - Motor Ordering Code

**GOLD CUP® Series - Application Manual
Piston Pumps & Motors**

Control & Displacement Features			
Control	Code	Control Feature	
2M	0	CETOP3, NG6 Valve, 110AC/60Hz with Hirschmann Connector ¹	
	1	CETOP3, NG6 Valve, 12VDC with Hirschmann Connector ¹	
	2	CETOP3, NG6 Valve, 240VAC/50Hz with Hirschmann Connector ¹	
	3	CETOP3, NG6 Valve, 110VAC/60Hz, Wiring Box ¹	
	4	CETOP3, NG6 Valve, 12VDC, Wiring Box ¹	
	5	CETOP3 (D03, NG6) Interface, No Valve ¹	
	6	CETOP3, NG6 Valve, 24VDC with Hirschmann Connector ¹	
	7	CETOP3, NG6 Valve, 110VAC/50Hz with Hirschmann Connector ¹	
5A	0	With Deadband ¹	
	1	Without Deadband ¹	
8A	0	75-250 PSI (5-17 Bar)	
	1	250-450 PSI (17-31 Bar)	
9A	0	24VDC ¹	
	1	12VDC ¹	
All Other	0	None	
Motor	Code	Reduced Displacement	
M*F M*G M*M M*N	0	Standard Cam (19°)	
	1	M6 with 17° Cam – 5.3 in ³ /rev (87cc/rev)	
		M7 with 17° Cam – 6.4 in ³ /rev (105 cc/rev)	
		M8 with 17° Cam – 7.1 in ³ /rev (116 cc/rev)	
		M11 with 17° Cam – 9.7 in ³ /rev (160 cc/rev)	
		M14 with 17° Cam – 12.5 in ³ /rev (205 cc/rev)	
	2	M24 with 17° Cam – 22.0 in ³ /rev (360 cc/rev)	
		M30 with 17° Cam – 27.2 in ³ /rev (446 cc/rev)	
		M6 with 15° Cam – 4.6 in ³ /rev (76 cc/rev)	
M7 with 15° Cam – 5.6 in ³ /rev (92 cc/rev)			
3	M8 with 15° Cam – 6.2 in ³ /rev (102 cc/rev)		
	M11 with 15° Cam – 8.5 in ³ /rev (140 cc/rev)		
	M14 with 15° Cam – 10.9 in ³ /rev (179 cc/rev)		
M6	M7	M8	
	M6 with 13° Cam – 4.0 in ³ /rev (66 cc/rev)	M7 with 13° Cam – 4.8 in ³ /rev (79 cc/rev)	M8 with 13° Cam – 5.3 in ³ /rev (88 cc/rev)

Code	Special Modifications
Omit	None
NP	No Paint
M2	Other Special Modification (example: bronze caged barrel bearing for low viscosity fluids, tandem motors, etc.)
EX	ATEX APPROVED PUMP (May contain additional modifications. Contact tech support.)

Code	External Mounting
0	No External Motor Mounted
1	External Motor Mounted (must be separately specified) – Requires Special Modification “-M2”
2	ATEX Externally Mounted Motor

Code	External Drive
Omit	None (M*F/G/V/H units only)
A	SAE-A (SAE 82-2) – M6, 7, 8, 11, 14M/N/R/L only
B	SAE-B (SAE 101-2) – M6, 7, 8M/N/R/L SAE-B (SAE 101-2 & 101-4) – M11, 14, 24, 30M/N/R/L
C	SAE-C (SAE 127-2) – M6, 7, 8M/N/R/L SAE-C (SAE 127-2 & 127-4) – M11, 14, 24, 30M/N/R/L
D	SAE-D (SAE 152-4) – M11, 14, 24, 30M/N/R/L only
E	SAE-E (SAE 165-4) – M11, 14, 24, 30M/N/R/L only
F	SAE-F (SAE 177-4) – M24, 30M/N/R/L only
M	Blanking Plate-less Coupling

Code	Shuttle Valve Features
Omit	M*F/M/V/R Motors only
0	Without Orifices
2	With Orifices

 = Omit if not required

The items described in this document and other documents and descriptions provided by Parker Hannifin Corporation, Hydraulics Group, and its authorized distributors ("Seller") are hereby offered for sale at prices to be established by Seller. This offer and its acceptance by any customer ("Buyer") shall be governed by all of the following Terms and Conditions. Buyer's order for any item described in its document, when communicated to Seller verbally, or in writing, shall constitute acceptance of this offer. All goods or work described will be referred to as "Products".

1. Terms and Conditions. Seller's willingness to offer Products, or accept an order for Products, to or from Buyer is expressly conditioned on Buyer's assent to these Terms and Conditions and to the terms and conditions found on-line at www.parker.com/saleterms/. Seller objects to any contrary or additional term or condition of Buyer's order or any other document issued by Buyer.

2. Price Adjustments; Payments. Prices stated on the reverse side or preceding pages of this document are valid for 30 days. After 30 days, Seller may change prices to reflect any increase in its costs resulting from state, federal or local legislation, price increases from its suppliers, or any change in the rate, charge, or classification of any carrier. The prices stated on the reverse or preceding pages of this document do not include any sales, use, or other taxes unless so stated specifically. Unless otherwise specified by Seller, all prices are F.O.B. Seller's facility, and payment is due 30 days from the date of invoice. After 30 days, Buyer shall pay interest on any unpaid invoices at the rate of 1.5% per month or the maximum allowable rate under applicable law.

3. Delivery Dates; Title and Risk; Shipment. All delivery dates are approximate and Seller shall not be responsible for any damages resulting from any delay. Regardless of the manner of shipment, title to any products and risk of loss or damage shall pass to Buyer upon tender to the carrier at Seller's facility (i.e., when it's on the truck, it's yours). Unless otherwise stated, Seller may exercise its judgment in choosing the carrier and means of delivery. No deferment of shipment at Buyer's request beyond the respective dates indicated will be made except on terms that will indemnify, defend and hold Seller harmless against all loss and additional expense. Buyer shall be responsible for any additional shipping charges incurred by Seller due to Buyer's changes in shipping, product specifications or in accordance with Section 13, herein.

4. Warranty. Seller warrants that the Products sold hereunder shall be free from defects in material or workmanship for a period of eighteen months from the date of delivery to Buyer. The prices charged for Seller's products are based upon the exclusive limited warranty stated above, and upon the following disclaimer: **DISCLAIMER OF WARRANTY: THIS WARRANTY COMPRISES THE SOLE AND ENTIRE WARRANTY PERTAINING TO PRODUCTS PROVIDED HEREUNDER. SELLER DISCLAIMS ALL OTHER WARRANTIES, EXPRESS AND IMPLIED, INCLUDING MERCHANTABILITY AND FITNESS FOR A PARTICULAR PURPOSE.**

5. Claims; Commencement of Actions. Buyer shall promptly inspect all Products upon delivery. No claims for shortages will be allowed unless reported to the Seller within 10 days of delivery. No other claims against Seller will be allowed unless asserted in writing within 60 days after delivery or, in the case of an alleged breach of warranty, within 30 days after the date within the warranty period on which the defect is or should have been discovered by Buyer. Any action based upon breach of this agreement or upon any other claim arising out of this sale (other than an action by Seller for any amount due to Seller from Buyer) must be commenced within thirteen months from the date of tender of delivery by Seller or, for a cause of action based upon an alleged breach of warranty, within thirteen months from the date within the warranty period on which the defect is or should have been discovered by Buyer.

6. LIMITATION OF LIABILITY. UPON NOTIFICATION, SELLER WILL, AT ITS OPTION, REPAIR OR REPLACE A DEFECTIVE PRODUCT, OR REFUND THE PURCHASE PRICE. IN NO EVENT SHALL SELLER BE LIABLE TO BUYER FOR ANY SPECIAL, INDIRECT, INCIDENTAL OR CONSEQUENTIAL DAMAGES ARISING OUT OF, OR AS THE RESULT OF THE SALE, DELIVERY, NON-DELIVERY, SERVICING, USE OR LOSS OF USE OF THE PRODUCTS OR ANY PART THEREOF, OR FOR ANY CHARGES OR EXPENSES OF ANY NATURE INCURRED WITHOUT SELLER'S WRITTEN CONSENT, EVEN IF SELLER HAS BEEN NEGLIGENT, WHETHER IN CONTRACT, TORT OR OTHER LEGAL THEORY. IN NO EVENT SHALL SELLER'S LIABILITY UNDER ANY CLAIM MADE BY BUYER EXCEED THE PURCHASE PRICE OF THE PRODUCTS.

7. Contingencies. Seller shall not be liable for any default or delay in performance if caused by circumstances beyond the reasonable control of Seller.

8. User Responsibility. The user, through its own analysis and testing, is solely responsible for making the final selection of the system and Product and assuring that all performance, endurance, maintenance, safety and warning requirements of the application are met. The user must analyze all aspects of the application and follow applicable industry standards and Product information. If Seller provides Product or system options, the user is responsible for determining that such data and specifications are suitable and sufficient for all applications and reasonably foreseeable uses of the Products or systems.

9. Loss to Buyer's Property. Any designs, tools, patterns, materials, drawings, confidential information or equipment furnished by Buyer or any other items which become Buyer's property, may be considered obsolete and may be destroyed by Seller after two consecutive years have elapsed without Buyer placing an order for the items which are manufactured using such property. Seller shall not be responsible for any loss or damage to such property while it is in Seller's possession or control.

10. Special Tooling. A tooling charge may be imposed for any special tooling, including without limitation, dies, fixtures, molds and patterns, acquired to manufacture Products. Such special tooling shall be and remain Seller's property notwithstanding payment of any charges by Buyer. In no event will Buyer acquire any interest in apparatus belonging to Seller which is utilized in the manufacture of the Products, even if such apparatus has been specially converted or adapted for such manufacture and notwithstanding any charges paid by Buyer. Unless otherwise agreed, Seller shall have the right to alter, discard or otherwise dispose of any special tooling or other property in its sole discretion at any time.

11. Buyer's Obligation; Rights of Seller. To secure payment of all sums due or otherwise, Seller shall retain a security interest in the goods delivered and this agreement shall be deemed a Security Agreement under the Uniform Commercial Code. Buyer authorizes Seller as its attorney to execute and file on Buyer's behalf all documents Seller deems necessary to perfect its security interest. Seller shall have a security interest in, and lien upon, any property of Buyer in Seller's possession as security for the payment of any amounts owed to Seller by Buyer.

12. Improper Use and Indemnity. Buyer shall indemnify, defend, and hold Seller harmless from any claim, liability, damages, lawsuits, and costs (including attorney fees), whether for personal injury, property damage, patent, trademark or copyright infringement or any other claim, brought by or incurred by Buyer, Buyer's employees, or any other person, arising out of: (a) improper selection, improper application or other misuse of Products purchased by Buyer from Seller; (b) any act or omission, negligent or otherwise, of Buyer; (c) Seller's use of patterns, plans, drawings, or specifications furnished by Buyer to manufacture Product; or (d) Buyer's failure to comply with these terms and conditions. Seller shall not indemnify Buyer under any circumstance except as otherwise provided.

13. Cancellations and Changes. Orders shall not be subject to cancellation or change by Buyer for any reason, except with Seller's written consent and upon terms that will indemnify, defend and hold Seller harmless against all direct, incidental and consequential loss or damage. Seller may change product features, specifications, designs and availability with notice to Buyer.

14. Limitation on Assignment. Buyer may not assign its rights or obligations under this agreement without the prior written consent of Seller.

15. Entire Agreement. This agreement contains the entire agreement between the Buyer and Seller and constitutes the final, complete and exclusive expression of the terms of the agreement. All prior or contemporaneous written or oral agreements or negotiations with respect to the subject matter are herein merged.

16. Waiver and Severability. Failure to enforce any provision of this agreement will not waive that provision nor will any such failure prejudice Seller's right to enforce that provision in the future. Invalidation of any provision of this agreement by legislation or other rule of law shall not invalidate any other provision herein. The remaining provisions of this agreement will remain in full force and effect.

17. Termination. This agreement may be terminated by Seller for any reason and at any time by giving Buyer thirty (30) days written notice of termination. In addition, Seller may by written notice immediately terminate this agreement for the following: (a) Buyer commits a breach of any provision of this agreement (b) the appointment of a trustee, receiver or custodian for all or any part of Buyer's property (c) the filing of a petition for relief in bankruptcy of the other Party on its own behalf, or by a third party (d) an assignment for the benefit of creditors, or (e) the dissolution or liquidation of the Buyer.

18. Governing Law. This agreement and the sale and delivery of all Products hereunder shall be deemed to have taken place in and shall be governed and construed in accordance with the laws of the State of Ohio, as applicable to contracts executed and wholly performed therein and without regard to conflicts of laws principles. Buyer irrevocably agrees and consents to the exclusive jurisdiction and venue of the courts of Cuyahoga County, Ohio with respect to any dispute, controversy or claim arising out of or relating to this agreement. Disputes between the parties shall not be settled by arbitration unless, after a dispute has arisen, both parties expressly agree in writing to arbitrate the dispute.

19. Indemnity for Infringement of Intellectual Property Rights. Seller shall have no liability for infringement of any patents, trademarks, copyrights, trade dress, trade secrets or similar rights except as provided in this Section. Seller will defend and indemnify Buyer against allegations of infringement of U.S. patents, U.S. trademarks, copyrights, trade dress and trade secrets ("Intellectual Property Rights"). Seller will defend at its expense and will pay the cost of any settlement or damages awarded in an action brought against Buyer based on an allegation that a Product sold pursuant to this Agreement infringes the Intellectual Property Rights of a third party. Seller's obligation to defend and indemnify Buyer is contingent on Buyer notifying Seller within ten (10) days after Buyer becomes aware of such allegations of infringement, and Seller having sole control over the defense of any allegations or actions including all negotiations for settlement or compromise. If a Product is subject to a claim that it infringes the Intellectual Property Rights of a third party, Seller may, at its sole expense and option, procure for Buyer the right to continue using the Product, replace or modify the Product so as to make it noninfringing, or offer to accept return of the Product and return the purchase price less a reasonable allowance for depreciation. Notwithstanding the foregoing, Seller shall have no liability for claims of infringement based on information provided by Buyer, or directed to Products delivered hereunder for which the designs are specified in whole or part by Buyer, or infringements resulting from the modification, combination or use in a system of any Product sold hereunder. The foregoing provisions of this Section shall constitute Seller's sole and exclusive liability and Buyer's sole and exclusive remedy for infringement of Intellectual Property Rights.

20. Taxes. Unless otherwise indicated, all prices and charges are exclusive of excise, sales, use, property, occupational or like taxes which may be imposed by any taxing authority upon the manufacture, sale or delivery of Products.

21. Equal Opportunity Clause. For the performance of government contracts and where dollar value of the Products exceed \$10,000, the equal employment opportunity clauses in Executive Order 11246, VEVRAA, and 41 C.F.R. §§ 60-1.4(a), 60-741.5(a), and 60-250.4, are hereby incorporated.

North America

Industrial

USA

Chicago Region

Naperville, IL
Tel: (630) 964 0796

Great Lakes Region

Fairlawn, OH
Tel: (330) 670 2680

Northeast Region

Lebanon, NJ
Tel: (908) 236 4121

Pacific Region

Buena Park, CA
Tel: (714) 228 2509

Southern Region

Alpharetta, GA
Tel: (770) 619 9767

Canada

Milton, Ontario
Tel: (905) 693 3000

México

Toluca, Edo. de México
Tel: (52) 72 2275 4200

Mobile

USA

Global Mobile

Lincolnshire, IL
Tel: (847) 821 1500

Central Region

Lincolnshire, IL
Tel: (847) 821 1500

Eastern Region

North Canton, OH
Tel: (330) 284 3355

Midwest Region

Hiawatha, IA
Tel: (319) 393 1221

Southern Region

Aledo, TX
Tel: (817) 441 1794

Western Region

Buena Park, CA
Tel: (714) 228 2509

Canada

Milton, Ontario
Tel: (905) 693 3000

México

Apodaca, N.L.
Tel: (52) 81 8156 6000

Truck

USA

Eastern Region

Cleveland, OH
Tel: (440) 519 1125

Western Region

San Ramon, CA
Tel: (925) 735 9573

Canada

Milton, Ontario
Tel: (905) 693 3000

México

Apodaca, N.L.
Tel: (52) 81 8156 6000

Europe

Austria

Wiener Neustadt
Tel: (43) 2622 23501 0

Belgium

Nivelles
Tel: (32) 67 280 900

Czech Republic and Slovakia

Klecaný
Tel: (420) 284 083 111

Denmark

Ballerup
Tel: (45) 4356 0400

Finland

Vantaa
Tel: (358) 20 753 2500

France

Contamine-sur-Arve
Tel: (33) 4 50 25 80 25

Germany

Kaarst
Tel: (49) 2131 4016 0

Greece

Athens
Tel: (30) 210 933 6450

Hungary

Budapest
Tel: (36) 1 220 4155

Ireland

County Dublin, Baldonnell
Tel: (353) 1 466 6370

Italy

Corsico, Milano
Tel: (39) 02 45 19 21

The Netherlands

Oldenzaal
Tel: (31) 541 585000

Norway

Ski
Tel: (47) 64 91 10 00

Poland

Warsaw
Tel: (48) 22 57 32400

Portugal

Leca da Palmeira
Tel: (351) 22 999 7360

Romania

Bucharest
Tel: (40) 21 252 1382

Russia

Moscow
Tel: (7) 495 580 9145

Slovenia

Novo Mesto
Tel: (386) 7 337 6650

Spain

Madrid
Tel: (34) 91 675 7300

Sweden

Spanga
Tel: (46) 8 597 95000

Ukraine

Kiev
Tel: (380) 44 494 2731

United Kingdom

Warwick,
Tel: (44) 1926 317878

Asia Pacific

Australia

Castle Hill
Tel: (61) 2 9634 7777

China

Beijing
Tel: (86) 10 6561 0520

Shanghai

Tel: (86) 21 5031 2525

Hong Kong

Tel: (852) 2428 8008

India

Mahape, Navi Mumbai
Tel: (91) 22 5613 7081

Korea

Seoul
Tel: (82) 2 559 0400

Malaysia

Subang Jaya
Tel: (60) 3 5638 1476

New Zealand

Mt. Wellington
Tel: (64) 9 574 1744

Japan

Tokyo
Tel: (81) 3 6408 3900

Singapore

Jurong Town
Tel: (65) 6 887 6300

Taiwan

Taipei
Tel: (886) 2 2298 8987

Thailand

Bangkok
Tel: (662) 717 8140

Middle East

United Arab Emirates

Abu Dhabi
Tel: (971) 2 678 8587

Latin America

Pan American Division

Miami, FL
Tel: (305) 470 8800

Argentina

Buenos Aires
Tel: (54) 33 2744 4129

Brazil

Cachoeirinha RS
Tel: (55) 51 3470 9144

Venezuela

Caracas
Tel: (58) 212 238 5422

Africa

South Africa

Kempton Park
Tel: (27) 11 961 0700

